



*Drive with Speed,
Quality and Confidence*



NOTES:

What Makes Us ÜberGrade?



Drive with Speed, Quality and Confidence



**RECESSED
STAR DRIVE**

Zero Stripping, with (6) points of contact

CEE THREAD™

Enlarges hole to reduce splitting

W-CUT™

Low torque, smoother drive

ZIP-TIP™

No pre-drilling,
faster penetration



IBC/IRC
COMPLIANT



**Case Hardened Steel for high tensile,
torque and shear strength.**

**Full breadth of line meeting remodeling and new
construction fastening needs for: Decks, Framing,
Trim, Cabinets, Windows, Doors and more.**

BUILDING CODE APPROVED—for structural use in treated lumber. GRK screws have been evaluated for structural and AC257 corrosion resistance to be in compliance with IBC/IRC specifications. That's why all our fasteners come with a limited lifetime warranty, so you can rest assured your installations will last the life of your project.

FOR THE MOST CORROSION RESISTANCE—GRK recommends the use of *PHEINOX™* Stainless Steel screws, especially in tropical wood, cedar, below ground grade treated lumber, pool/hot tub/sauna and applications within 15 miles of coastline.



Call our toll free number 800-387-9692 or visit www.itwconstruction.ca for general information.
Visit GRK Fasteners web site www.grkfasteners.com for the most current product and technical information.



Selection Guide

Fastener Selection Guide and Quick Reference Product Locator

Always build your project according to current ICC (International Code Council) specifications. GRK's Climatek™ coating meets or exceeds standards, including AC257, for use in various type of preservative treated wood.

Please view ICC Report #ESR-2442, ESR-3201 and ESR-3251 for more details. Visit <http://www.grkfasteners.com/index.php/en/techdata/code-approvals>.

No pre-drilling required for most GRK products, unless required or specified by building material. Always place deck boards with outer edge of growth rings facing up (bark side up). Do not use deck cleaners which contain bleach with coated metals. Consult building material supplier's/manufacturer's recommendations for exact instructions. Decking screws should be countersunk 1/8".



R4™ MULTI-PURPOSE FRAMING SCREWS:

Frame with ease and confidence. Multi-use screw for wood, particle board, sheet metal, cement fibre board, laminate and wood decking and melamine. They are self tapping eliminating pre-drilling featuring a countersinking head with cutting teeth, W-Cut™ for reducing torque, CEE Thread™ for no splitting and our Climatek™ AC257 code approved coating. For deck boards consisting of pressure treated lumber, cedar & redwood use #9 or #10 gauge screws.

For Southern Yellow Pine use #10. For use in all applications including pressure treated lumber. [Some sizes come in PHEINOX™ stainless steel.](#)

They are ESR code approved under ICC Report ESR-3201.

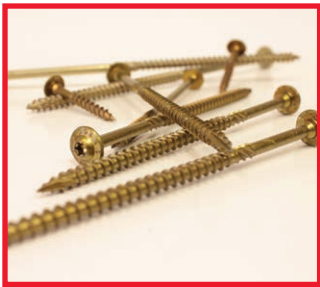

RSS™ RUGGED STRUCTURAL SCREWS:

Speedy lag bolt alternative with Immense drawing power. Ideal for use anywhere you would use a traditional lag screw and more, but with no pre-drilling required. For use in all applications including pressure treated lumber. They are self tapping eliminating pre-drilling featuring a washer head with cutting teeth, W-Cut™ for reducing torque, CEE Thread™ for no splitting and our Climatek™ AC257 code approved coating. They are ESR code approved under ICC Report ESR-2442. [Some sizes come in PHEINOX™ stainless steel.](#)

RSS™ JTS: Joist & Truss Fastener: Used for joists and trusses.

RSS™ LPS: Panel Fastener: For Structural Insulated Panel Systems.

RSS™ LTF: Timber Frame Fastener: Designed specifically for the Log Home & Timber frame market.



KAMELEON™ COMPOSITE DECK SCREWS:

Heads blend in with decking with no mushrooming effect. Use in plastic or composite decking. They come in a variety of deck matching colours of which Pebble Grey, Saddle, Woodland Brown and Madeira are approved for use with Trex Select™ deck boards.

The Kameleon screws are self tapping featuring fibre trapping rings, a countersinking head with cutting teeth, CEE Thread™, W-Cut™ threads for reduced torque and our Climatek™ AC257 code approved coating. They are ESR code approved under ICC Report ESR-3201.



FIN/TRIM™ TRIM HEAD SCREWS:

Smallest head on the market for a clean finish. Perfect for all interior and exterior finishing applications including deck rails, exterior wood trim, stairs, banisters, window and door trim, base boards, crown moulding and joining cabinets. For use in all applications including pressure treated lumber.

They are self-tapping eliminating pre-drilling featuring the W-Cut™ threads for reduced torque, and our Climatek™ AC257 code approved coating. They are ESR code approved under ICC Report ESR-3201.

[Some sizes come in PHEINOX™ stainless steel.](#)

Fastener Selection Guide and Quick Reference Product Locator

RT COMPOSITE™ TRIM HEAD SCREWS:

Reverse thread design prevent mushrooming for a clean finish. Engineered for use in exterior applications including classic composite trim and decking, cPVC trim and moulding. For use in all applications including pressure treated lumber. RT™ Composite Trim screws are self-tapping eliminating pre-drilling featuring the W-Cut™ threads for reduced torque, and our Climatek™ AC257 code approved coating. They are ESR code approved under ICC Report ESR-3201.

Some sizes come in *PHEINOX™* stainless steel.



LOW PROFILE CABINET™ SCREWS:

Built in washer head presses in flush against any material. Used for cabinet and vinyl siding installation. These unique screws are thin enough to prevent most material splitting, while providing sufficient strength to guarantee a secure installation.

They are self tapping eliminating pre-drilling featuring the W-Cut™ threads for reduced torque and our Climatek™ AC257 code approved coating.



PHEINOX™ STAINLESS STEEL SCREWS:

For Strongest corrosion resistance. Recommended for use in tropical wood, around pools, hot tubs, sauna and sea-side type applications. Available in 305 grade stainless steel.

The following GRK Screws are available in *PHEINOX™* Stainless Steel: R4™ Multi-Purpose Framing, RSS™ Rugged Structural Screws, Fin/Trim™ and RT Composite™ Trim Head Screws and Low Profile Cabinet™ Screws.



TOP STAR™ SHIM SCREWS:

For plumb installation of wooden door and window frames. No more shims! Other uses include cabinets, insulation, paneling and built-in-wall units.

The two-piece “unique screw within a screw” design reduces labour when installing wooden doors or windows. A unique 2 piece crown/bit allows for quick and easy driving.



VWS™ VINYL WINDOW SCREWS:

Install replacement vinyl windows without the use of shims! Allows for quick, easy and precise leveling capabilities.

The self-tapping screw features a patented washer head design with a unique edge under the screw head designed to capture the vinyl extrusion during penetration. The secondary shoulder allows for adjustments and fine tuning of framework until the window is plumb.

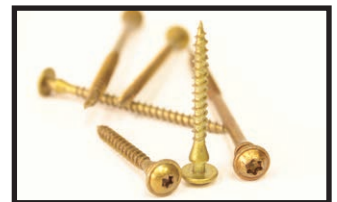

CALIBURN™ SCREWS:

Heavy duty concrete and masonry fastener. For attaching a variety of materials and fixtures to concrete. Easy driving high carbon steel allows the screws to be reinserted as they create threads while being driven into the concrete. Proper pre-drilling with correct drill bit required. Caliburn™ screws are Climatek™ AC257 code approved coating. The Caliburn™XL is ESR code approved under ICC Report ESR-3251.

Caliburn Screw: Tapered concrete screw for securing wood.

Caliburn™ PH Screw: Pan head concrete screw for a more aesthetic look

Caliburn™ XL Screws: Washer head style concrete screw for strong connections



Multi-Purpose Framing Screws
Frame with Ease and Confidence



DESCRIPTION/SUGGESTED SPECIFICATIONS

Multi-Purpose Framing Screws—

GRK's R4™ self-countersinking screw has a patented underhead with saw-blade like cutting teeth and six self-contained cutting pockets. Together they act similar to a circular saw-blade, transporting the drill dust away from the edge of the screw hole while cutting a perfectly clean hole into even the most brittle materials without cracking any surface treatment.

ÜberGrade™

This design enhances the R4™'s versatility by allowing the fastener to countersink into even the hardest woods. The head of the screw closes the hole off with precision, leaving no damaged fibres around the head.



R4™ screws 2" and longer have a four threaded CEE Thread. This enlarges the screw hole for the non-threaded portion of the fastener, allowing the wood to settle easily. It increases the screw's drawing strength and reduces the friction on the screw shank that lowers the driving torque.

ADVANTAGES

- **Recessed Star Drive:** Zero Stripping, with 6 points of contact.
- **CEE Thread:** Enlarges hole to reduce splitting.
- **W-Cut™:** Low torque, smoother drive.
- **Zip-Tip™:** No pre-drilling, faster penetration.
- **Cutting Pockets:** provide a clean hole, reduces splitting, and bore with precision.
- **ESR-3201 Approved** for structural application.
- **Case Hardened Steel:** for high tensile, torque and shear strength.
- **Climatek™ Coating** is AC257 code approved for use in treated lumber.
- For interior/exterior use in; wood, plastic, cement fibre board, particle board, sheet metal, wood decking and melamine.
- Also available in **PHEINOX™** 305 grade Stainless Steel.

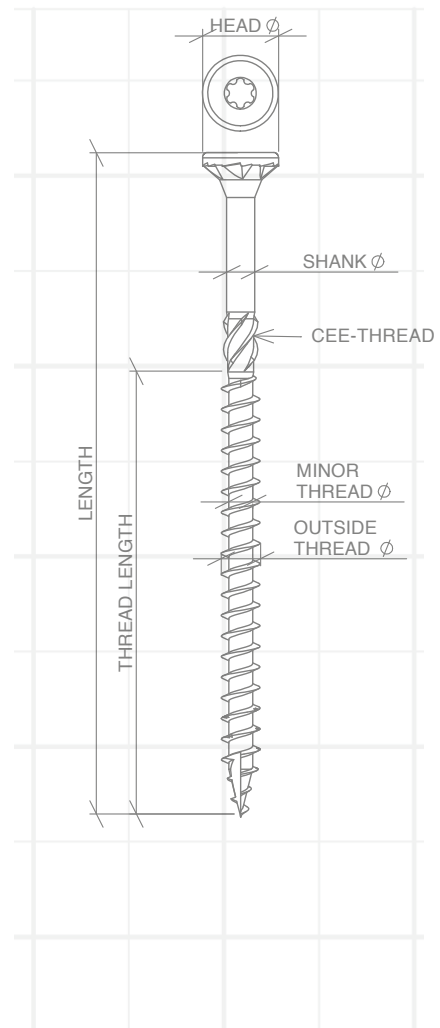

APPROVALS/LISTING



APPLICATIONS



SELECTION CHART



T-15



T-25



T-25



T-25

U.S. (STD.) SIZE (DIA. X LENGTH)	METRIC SIZE (DIA. X LENGTH)	BULK PART NO.	BULK BOX QTY.	PRO-PAK PART NO.	PRO-PAK PAIL QTY.	HANDY-PAK PART NO.	HANDY-PAK CTN. SIZE/QTY.
#6 x 2"	3.5 x 50	00059	5,400				
#8 x 1"						02067*	S/100
#8 x 1-1/4"	4.0 x 30	00069	10,000			02069	S/100
#8 x 1-1/2"	4.0 x 40	00073	6,500	01073	1,000	02073	S/100
#8 x 1-3/4"	4.0 x 45	00075	6,000	01075	925		
#8 x 2"	4.0 x 50	00077	4,500	01077	850	02077	S/100
#8 x 2-1/2"	4.0 x 63	00079	3,500			02079	S/100
#9 x 1-1/4"	4.5 x 30	00091	8,000			02091	S/100
#9 x 1-1/2"	4.5 x 40	00095	5,200				
#9 x 1-3/4"	4.5 x 45	00097	4,500			02097	S/100
#9 x 2"	4.5 x 50	00099	3,700	01099	690	02099	M/100
#9 x 2-1/2"	4.5 x 63	00101	2,900	01101	575	02101	M/100
#9 x 2-3/4"	4.5 x 70	00103	2,000	01103	480		M/100
#9 x 3-1/8"	4.5 x 80	00105	1,900	01105	425	02105	M/100
#10 x 2"	5.0 x 50	00131	3,200				
#10 x 2-1/2"	5.0 x 63	00133	2,500	01133	470	02133	M/100
#10 x 2-3/4"	5.0 x 70	00135	2,000	01135	395		
#10 x 3-1/8"	5.0 x 80	00137	1,500	01137	350	02137	M/100
#10 x 3-1/2"	5.0 x 90	00139	1,200	01139	300	02139	M/50
#10 x 4"	5.0 x 100	00141	1,000	01141	270	02141	M/50
#10 x 4-3/4"	5.0 x 120	00143	800	01143	230	02143	M/50
#12/14 x 3-1/8"	6.0 x 80	00161	1,200				
#12/14 x 4"	6.0 x 100	00165	800	01165	190		
#12/14 x 5-5/8"	6.0 x 140	00173	600			02173	M/50
#12/14 x 6-3/8"	6.0 x 160	00177	1,000			02177	M/9
#12/14 x 7-1/4"	6.0 x 180	00179	1,000			02179	M/9
#12/14 x 8"	6.0 x 200	00181	500			02181	M/9
#12/14 x 10"	6.0 x 250					02187	M/12
#12/14 x 12"	6.0 x 300					02193	M/12

Some sizes available in **PHEINOX™** hardened Stainless Steel; refer to pages 26-27. 2" bit included in Pro-Paks, 1" bits in Handy-Paks.

*Does not come with the **Zip-Tip™** feature. **NOTE:** Pro-Paks need to be ordered in multiples of two.

Rugged Structural Screws
Speedy Lag Bolt Alternative with Immense Drawing Power

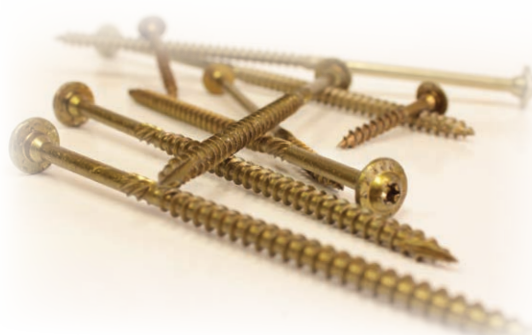

APPROVALS/LISTING



DESCRIPTION/SUGGESTED SPECIFICATIONS

Rugged Structural Screws—

GRK's RSS™ screw is made of specially hardened steel to provide you with high tensile, torque and shear strength. The sharp threads and points bite instantly into the material (including hardwood), reducing the splitting effect due to smaller shanks.

RSS™ screws that are 3" 1/8" and longer have CEE Threads which enlarge the screw hole for the non-threaded portion of the fastener, allowing the wood to settle easily and increases the screw's drawing strength. The CEE Thread also reduces the friction on the screw shank which can result in lowering the driving torque and the likelihood of splitting the wood. This is why the RSS™ screw is an efficient lag screw alternative.

ÜberGrade™

Our round head with built-in shield (washer type head) has no sharp edges like conventional lag screws. The added shoulder (nominal diameter) underneath the washer has the ability to center the RSS™ screw in pre-drilled hardware like hinges and connector plates.



RSS™ JTS - Used for joists and trusses

RSS™ LPS - For structural insulated panel systems

RSS™ LTF - Designed for log home and timber frame

ADVANTAGES

- **Recessed Star Drive:** Zero Stripping, with 6 points of contact.
- **CEE Thread:** Enlarges hole to reduce splitting.
- **W-Cut™:** Low torque, smoother drive.
- **Zip-Tip™:** No pre-drilling, faster penetration.
- **Washer Head:** for immense holding power.
- **Cutting Pockets:** provide a clean hole, reduces splitting, and bore with precision.
- **ESR-2442 Approved** for structural application.
- **Case Hardened Steel:** for high tensile, torque and shear strength.
- **Climatek™ Coating is AC257** code approved for use in treated lumber.
- For interior/exterior use in; carrying beams, ledger boards, stair rails, deck posts, playground equipment and other professional applications.
- Also available in **PHEINOX™** 305 grade Stainless Steel.
- **Advantages:** Factored Resistances as per CSA – 086 – 14

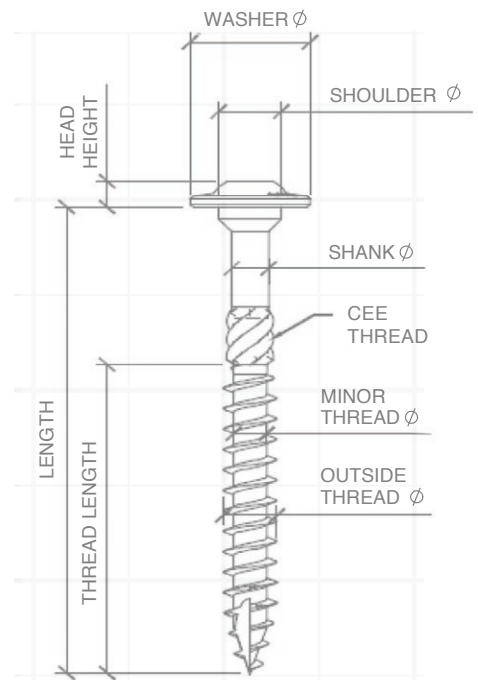

SELECTION CHART



T-25



T-25



T-30



T-40



T-25



T-40

SHANK DIAMETER	THREAD DIAMETER	LENGTH	BULK PART NO.	BULK BOX QTY.	PRO-PAK PART NO.	PRO-PAK PAIL QTY.	HANDY-PAK PART NO.	HANDY-PAK CTN. SIZE/QTY.
0.138	0.194 (#10)	1-1/2"	10127*	2,300				
		2"	10131*	1,600				
		2-1/2"					12133	M/50
		2-3/4"	10135	1,000				
		3-1/8"	10137	800			12137	M/50
0.169	0.25 (1/4)	1-1/2"	10151*	1,000			12151	M/50
		2"	10155*	800			12155	M/50
		2-1/2"	10157	700			12157	M/50
		3-1/8"	10161	500			12161	M/50
		3-1/2"	10163	400			12163	M/50
0.1988	0.3125 (5/16)	2-1/2"	10217	600	12217	100		
		2-3/4"	10219	500	12219	100		
		3-1/8"	10221	500	12221	100		
		3-1/2"	10223	500	12223	100		
		4"	10225	400	12225	100		
		5-1/8"	10231	300	12231	50		
		6"	10235	300	12235	50		
0.2228	0.375 (3/8")	3-1/8"	10273	400	12273	50		
		4"	10275	400	12275	50		
		5-1/8"	10278	300	12278	50		
		6"	10281	300	12281	50		
		7-1/4"	10285	200	12285	50		
		8"	10287	300	12287	50		
		10"	10293	300	12293	50		
		12"	10299	300	12299	50		
		14-1/8"	10307	200	12307	50		
		16"	10311	100	12311	50		
RSS™ JTS – JOIST AND TRUSS SCREW								
0.173	0.25 (1/4)	3-3/8"	91727†	400				
		5"	91735	300			93735	9/50
		6-3/4"	91743	300			93743	9/50
RSS™ LPS – PANEL SCREW								
0.172	0.25 (1/4)	8"	91181	500			93181	9/50
RSS™ LTF – TIMBER FRAME SCREW								
0.22	0.31 (3/8)	8"	91287	300			93287	M/50
		10"	91293	300			93293	M/50
		12"	91299	300			93299	M/50
		15"	91308	300			93308	M/50
		18"	91321	100			93321	M/25
		20"					93323	M/25

RSS™ BLISTER-PAK				
SHANK DIAMETER	THREAD DIAMETER	LENGTH	Part No.	QTY
0.1988	0.3125 (5/16)	3-1/8"	13221	15
		4"	13225	12
		5-1/8"	13231	10
		6"	13235	8
0.2228	0.375 (3/8)	8"	13287	3

RSS™ SMALLER HANDY-PAK				
SHANK DIAMETER	THREAD DIAMETER	LENGTH	Part No.	QTY
0.1988	0.3125 (5/16)	2-1/2"	14217	M/25
		3-1/8"	14221	M/25
		4"	14225	M/25
		5-1/8"	14231	M/20
		6"	14235	M/20

Some sizes available in **PHEINOX™** hardened Stainless Steel; refer to pages 26-27. **NOTE:** Pro-Paks need to be ordered in multiples of two.
 *Does not come with the **Zip-Tip™** feature. †Does not have the added **CEE-THREAD™** feature. 2" bit included in Pro-Paks, 1" bits in Handy-Paks.

Conversion Guide

GRK RSS vs. Lag Bolt

No more
pre-drilling...
Just grab a screw
and drill!!

Convert from a lag screw to GRK RSS Fasteners

PERFORMANCE DATA

(Compliant for use with Canadian National Building Code)

FACTORED RESISTANCES PERFORMANCE COMPARISON FOR D.FIR MEMBERS^(1,2,3,4,5)
APPLICATION: 2" LEDGER BOARD TO 2" RIM BOARD

LAG SCREWS				GRK SCREWS		
LAG SIZE	LENGTH	SHEAR RESISTANCE	PULL-OUT	TYPE OF SCREW	SHEAR RESISTANCE	PULL-OUT
1/4"	3	171	360	GRK RSS (3") (10273)	366	517
1/4"	4	200	360	GRK RSS (4") (10275)	466	517
3/8"	3	249	618	GRK RSS (3") (10273)	366	517
3/8"	4	322	618	GRK RSS (4") (10275)	466	517
1/2"	3	320	779	GRK RSS (3") (10273)	366	517
1/2"	4	427	779	GRK RSS (4") (10275)	466	517
5/8"	3	385	920	GRK RSS (3") (10273)	366	517
5/8"	4	513	920	GRK RSS (4") (10275)	466	517

¹ Lag Screw Factored Resistances have been developed in accordance with 12.6 CSA 086-14. Apply adjustment factors where applicable.

² Factored withdrawn resistance shown assume the entire threaded portion of the screw is installed in to the main member

³ Minimum spacing, edge and end distances shall be in accordance with 12.6 .2 CSA 086-14

⁴ GRK RSS Screw spacing must comply with 12.11.5 CSA 086-14 (See Spacing Tables)

⁵ Dimensions of Lag screw based on Table 15 & 16 ASME B18.2.1-2012

EXAMPLE DECK DESIGN: ATTACHING LEDGER BOARD TO YOUR HOUSE!

Assumptions:

- Deck Span = 8' out from the house
- 10' Wide
- LL = 40 PSF; DL = 10 PSF

Total lateral resistance required = 2900 lbs

Possible Solutions

Using 1/4" by 3" Lag Bolts = 2900 / 242 = 12 lags

Using 3/8" by 3" Lag Bolts = 2900 / 249 = 12 Lags (see example below)

Using 1/2" by 3" Lag Bolts = 2900 / 320 = 9

Using 5/8" by 3" Lag Bolts = 2900 / 385 = 8

Using 3/8" * 3.125 RSS = 2900 / 366 = 8 screws (see example below)

LAG SOLUTION: 12 LAG SCREWS

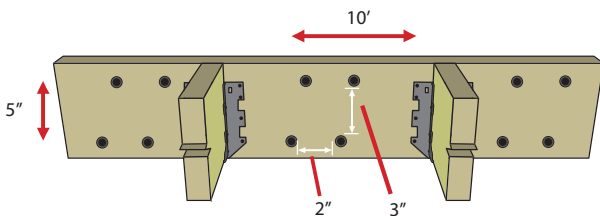

RSS SOLUTION: 8 RSS SCREWS¹ NO PRE-DRILLING

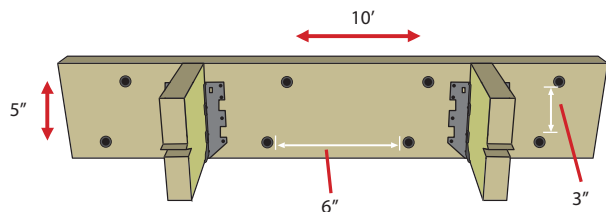

¹ RSS Spacing must comply with 12.11.5 CSA 086-14

Factored Resistances (RSS 1/4")

FACTORED RESISTANCES FOR D.FIR MEMBERS (LBS)

SIZE			MODEL/ BULB PART NO.	THREADED LENGTH (in)	THREADED LENGTH (mm)	D-FIR LARCH ¹										0.48	
SHANK DIAMETER	THREAD DIA (in)	LENGTH (in)				FACTORED LATERAL REISTANCE (Kd=1.00) WOOD SIDE MEMBER THICKNESS (mm & in)											WITHDRAWL (LBS)
						38.1 1.5	50.8 2	63.5 2.5	76.2 3	88.9 3.5	101.6 4	114.3 4.5	127 5	152.4 6	203.2 8		
.169	1/4	2.5	10217	1.5	38.1	225	---	---	---	---	---	---	---	---	---	---	418
		3.125	22400	2	50.8	281	253	---	---	---	---	---	---	---	---	---	558
		3.5	10163	2.75	69.85	300	300	225	---	---	---	---	---	---	---	---	767

¹ See Foot Notes below

FACTORED RESISTANCES FOR S-P-F MEMBERS (LBS)

SIZE			MODEL/ BULB PART NO.	THREADED LENGTH (in)	THREADED LENGTH (mm)	SPRUCE-PINE-FIR ^(1,2,3,4,5)										0.42	
SHANK DIAMETER	THREAD DIA (in)	LENGTH (in)				FACTORED LATERAL REISTANCE (Kd=1.00) WOOD SIDE MEMBER THICKNESS (mm & in)											WITHDRAWL (LBS)
						38.1 1.5	50.8 2	63.5 2.5	76.2 3	88.9 3.5	101.6 4	114.3 4.5	127 5	152.4 6	203.2 8		
.169	1/4	2.5	10217	1.5	38.1	197	---	---	---	---	---	---	---	---	---	---	330
		3.125	22400	2	50.8	246	222	---	---	---	---	---	---	---	---	---	440
		3.5	10163	2.75	69.85	268	268	197	---	---	---	---	---	---	---	---	605

¹ Factored resistances shown have been developed in accordance with 12.11 CSA 086-14 based on testing per ICC-ES AC233. Apply the adjustment factors Kd, Ksf and Kt as per 15.2.2 where applicable. Do not install in end grain.

² Factored withdrawal resistances shown are only applicable to short term loads as per 12.11.5 CSA 086-14

³ Factored withdrawal resistances shown assume the entire threaded portion of the screw is installed into the main member.

⁴ Minimum spacing, edge and end distances shall be in accordance with 12.9.2.1 CSA 086-14 using the corresponding shank diameter. See table below.

⁵ Divide table value by 224.8 to convert to kN (1Kn = 224.8 lbs)

STANDARD RSS SCREW (SIZE 1/4")

	GEOMETRY	MINIMUM DIMENSIONS (in)	
		D. FIR-L	S-P-F
A	Spacing parallel to grain	5.0	4.0
B	End distance parallel to grain	4.0	3.0
C	Spacing perpendicular to grain	2.5	2.0
D	Edge distance perp to grain	1	1.0

¹ Additional screws may be staggered diagonally between rows.

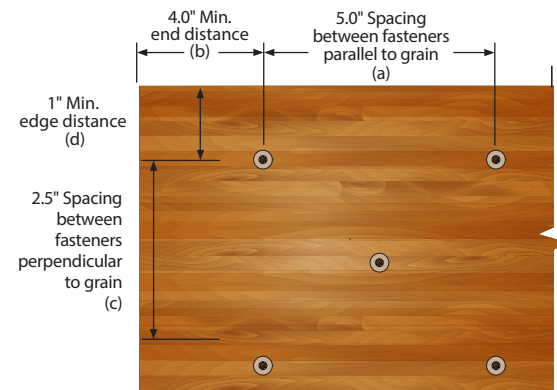

D-Fir Larch Spacing Requirements¹

Factored Resistances (RSS 1/4") continued on page G12

RSS™ Rugged Structural Screws

Factored Resistances (RSS 1/4") continued from page G 11

MAXIMUM FASTENER SPACING FOR DECK LEDGER TO RIM BOARD 1/4" (in.)

LEDGER SIZE	MODEL	RIM BOARD	SPECIFIED LIVE LOAD psf (kPa)	MAXIMUM DECK JOIST SPAN (ft.) ^(1,2,3,4,5,6)					
				6	8	10	12	14	16
2x	10157	2x SPF	40 (1.9)	11.0	8.0	6.5	5.5	4.5	4.0
		2x SPF	50 (2.4)	9.0	7.0	5.5	4.5	4.0	3.5
		2x SPF	100 (4.8)	5.0	3.5	3.0	2.5	2.0	2.0

¹ Solid Sawn lumber ledger board shall be a minimum of 2 x 8. Spacings apply to S-P-F, Hem-Fir or D.Fir-L

² Spacing requirements are based on testing as per ICC-ES and modified to meet the requirements of 12.9.2.1 CSA 086-14 assuming dry service conditions.

³ Tabulated values are based on the listed specified live loads in combination with 10 psi (.50 kPa) specified dead load.

⁴ RSS Screws shall be placed in accordance with screw spacing shown in tables above.

⁵ Factored resistances shown assume the entire threaded portion of the screw is installed into the main member.

⁶ Spacing calculated based on factored resistance shown in tables above.

Factored Resistances (RSS 5/16")

FACTORED RESISTANCES FOR D.FIR MEMBERS (LBS)

SIZE			MODEL/ BULB PART NO.	THREADED LENGTH (in)	THREADED LENGTH (mm)	D-FIR LARCH ¹										WITHDRAWAL (LBS)	
SHANK DIAMETER	THREAD DIA (in)	LENGTH (in)				FACTORED LATERAL RESISTANCE (Kd=1.00) WOOD SIDE MEMBER THICKNESS (mm & in)											
			38.1	50.8	63.5	76.2	88.9	101.6	114.3	127	152.4	203.2	0.48				
				1.5	2	2.5	3	3.5	4	4.5	5	6		8			
.1988	0.3125	2.5	10217	1.5	38.1	263	---	---	---	---	---	---	---	---	---	476	
		2.75	10219	1.75	44.45	289	---	---	---	---	---	---	---	---	---	---	555
		3.125	10221	2.125	53.975	329	296	---	---	---	---	---	---	---	---	---	675
		3.5	10223	2.5	63.5	368	368	263	---	---	---	---	---	---	---	---	794
		4	10225	2.75	69.85	398	421	394	263	398	---	---	---	---	---	---	873
		5.125	10231	3.5	88.9	398	451	481	464	411	296	---	---	---	---	---	1111
		6	10235	3.875	98.425	398	451	481	481	481	451	394	263	---	---	---	1230

¹ See Foot Notes below

FACTORED RESISTANCES FOR S-P-F MEMBERS (LBS)

SIZE			MODEL/ BULB PART NO.	THREADED LENGTH (in)	THREADED LENGTH (mm)	SPRUCE-PINE-FIR ^(1,2,3,4,5)										WITHDRAWAL (LBS)	
SHANK DIAMETER	THREAD DIA (in)	LENGTH (in)				FACTORED LATERAL RESISTANCE (Kd=1.00) WOOD SIDE MEMBER THICKNESS (mm & in)											
			38.1	50.8	63.5	76.2	88.9	101.6	114.3	127	152.4	203.2	0.42				
				1.5	2	2.5	3	3.5	4	4.5	5	6		8			
.1988	0.3125	2.5	10217	1.5	38.1	230	---	---	---	---	---	---	---	---	---	376	
		2.75	10219	1.75	44.45	253	---	---	---	---	---	---	---	---	---	---	439
		3.125	10221	2.125	53.975	287	259	---	---	---	---	---	---	---	---	---	533
		3.5	10223	2.5	63.5	322	322	230	---	---	---	---	---	---	---	---	627
		4	10225	2.75	69.85	357	368	345	230	357	---	---	---	---	---	---	689
		5.125	10231	3.5	88.9	357	403	439	415	369	259	---	---	---	---	---	877
		6	10235	3.875	98.425	357	403	439	439	439	403	345	230	---	---	---	971

¹ Factored resistances shown have been developed in accordance with 12.11 CSA 086-14 based on testing per ICC-ES AC233. Apply the adjustment factors Kd, Ksf and Kt as per 15.2.2 where applicable. Do not install in end grain.

² Factored withdrawal resistances shown are only applicable to short term loads as per 12.11.5 CSA 086-14

³ Factored withdrawal resistances shown assume the entire threaded portion of the screw is installed into the main member.

⁴ Minimum spacing, edge and end distances shall be in accordance with 12.9.2.1 CSA 086-14 using the corresponding shank diameter. See table on page G 13.

⁵ Divide table value by 224.8 to convert to kN (1Kn = 224.8 lbs)

Factored Resistances (RSS 5/16") continued on page G 13

Factored Resistances (RSS 5/16") continued from page G 12

STANDARD RSS SCREW (SIZE 5/16")

	GEOMETRY	MINIMUM DIMENSIONS (in)	
		D. FIR-L	S-P-F
A	Spacing parallel to grain	6.0	5.0
B	End distance parallel to grain	4.0	3.0
C	Spacing perpendicular to grain	3.0	2.0
D	Edge distance perp to grain	1.5	1.0

¹ Additional screws may be staggered diagonally between rows.

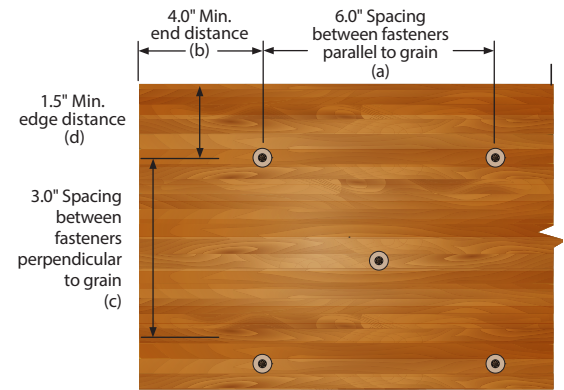

D-Fir Larch Spacing Requirements¹

MAXIMUM FASTENER SPACING FOR DECK LEDGER TO RIM BOARD 5/16" (in.)

LEDGER SIZE	MODEL	RIM BOARD	SPECIFIED LIVE LOAD psf (kPa)	MAXIMUM DECK JOIST SPAN (ft.) ^(1,2,3,4,5,6)					
				6	8	10	12	14	16
2x	10221	2x SPF	40 (1.9)	16.0	12.0	9.5	8.0	7.0	6.0
		2x SPF	50 (2.4)	13.0	10.0	8.0	6.5	5.5	5.0
		2x SPF	100 (4.8)	7.0	5.5	4.0	3.5	3.0	2.5

¹ Solid Sawn lumber ledger board shall be a minimum of 2 x 8. Spacings apply to S-P-F, Hem-Fir or D.Fir-L

² Spacing requirements are based on testing as per ICC-ES and modified to meet the requirements of 12.9.2.1 CSA 086-14 assuming dry service conditions.

³ Tabulated values are based on the listed specified live loads in combination with 10 psi (.50 kPa) specified dead load.

⁴ RSS Screws shall be placed in accordance with screw spacing shown in tables above.

⁵ Factored resistances shown assume the entire threaded portion of the screw is installed into the main member.

⁶ Spacing calculated based on factored resistance shown in tables above.

Factored Resistances (RSS 3/8")

FACTORED RESISTANCES FOR D.FIR MEMBERS (LBS)

SIZE			MODEL/ BULB PART NO.	THREADED LENGTH (in)	THREADED LENGTH (mm)	D-FIR LARCH ¹										0.48 WITHDRAWL (LBS)
SHANK DIAMETER	THREAD DIA (in)	LENGTH (in)				FACTORED LATERAL RESISTANCE (Kd=1.00) WOOD SIDE MEMBER THICKNESS (mm & in)										
						38.1 1.5	50.8 2	63.5 2.5	76.2 3	88.9 3.5	101.6 4	114.3 4.5	127 5	152.4 6	203.2 8	
.2228	0.375	3.125	10273	1.5	38.1	366	329	---	---	---	---	---	---	---	---	517
		4	10275	2.75	69.85	466	468	439	---	---	---	---	---	---	---	949
		5.125	10278	3.5	88.9	466	525	582	540	476	329	---	---	---	---	1207
		6	10281	4	101.6	466	525	582	582	466	466	466	---	---	---	1380
		7.25	10285	4.5	114.3	466	525	582	582	466	582	582	554	366	---	1552
		8	10287	4.375	111.125	466	525	582	582	582	582	582	582	525	---	1509
		10	10293	5	127	466	525	582	582	582	582	582	582	582	525	1725
		12	10299	5.875	149.2	466	525	582	582	582	582	582	582	582	582	2027
		14.125	10307	5.875	149.2	466	525	582	582	582	582	582	582	582	582	2027
		16	10311	5.75	146.1	466	525	582	582	582	582	582	582	582	1984	

¹ See Foot Notes below

FACTORED RESISTANCES FOR S-P-F MEMBERS (LBS)

SIZE			MODEL/ BULB PART NO.	THREADED LENGTH (in)	THREADED LENGTH (mm)	SPRUCE-PINE-FIR ^(1,2,3,4,5)										0.42 WITHDRAWL (LBS)
SHANK DIAMETER	THREAD DIA (in)	LENGTH (in)				FACTORED LATERAL RESISTANCE (Kd=1.00) WOOD SIDE MEMBER THICKNESS (mm & in)										
						38.1 1.5	50.8 2	63.5 2.5	76.2 3	88.9 3.5	101.6 4	114.3 4.5	127 5	152.4 6	203.2 8	
.2228	0.375	3.125	10273	1.5	38.1	320	288	---	---	---	---	---	---	---	---	409
		4	10275	2.75	69.85	410	410	384	---	---	---	---	---	---	---	749
		5.125	10278	3.5	88.9	419	470	521	483	416	288	---	---	---	---	953
		6	10281	4	101.6	419	470	521	531	419	419	419	---	---	---	1089
		7.25	10285	4.5	114.3	419	470	521	531	419	531	531	496	320	---	1226
		8	10287	4.375	111.125	419	470	521	531	531	531	531	531	470	---	1192
		10	10293	5	127	419	470	521	531	531	531	531	531	531	470	1362
		12	10299	5.875	149.2	419	470	521	531	531	531	531	531	531	531	1600
		14.125	10307	5.875	149.2	419	470	521	531	531	531	531	531	531	531	1600
		16	10311	5.75	146.1	419	470	521	531	531	531	531	531	531	1566	

¹ Factored resistances shown have been developed in accordance with 12.11 CSA 086-14 based on testing per ICC-ES AC233. Apply the adjustment factors Kd, Ksf and Kt as per 15.2.2 where applicable. Do not install in end grain.

² Factored withdrawal resistances shown are only applicable to short term loads as per 12.11.5 CSA 086-14

³ Factored withdrawal resistances shown assume the entire threaded portion of the screw is installed into the main member.

⁴ Minimum spacing, edge and end distances shall be in accordance with 12.9.2.1 CSA 086-14 using the corresponding shank diameter. See table on page G 15.

⁵ Divide table value by 224.8 to convert to kN (1Kn = 224.8 lbs)

Factored Resistances (RSS 3/8") continued on next page

Factored Resistances (RSS 3/8") continued from page G 14

STANDARD RSS SCREW (SIZE 3/8" OR LTF)

	GEOMETRY	MINIMUM DIMENSIONS (in)	
		D. FIR-L	S-P-F
A	Spacing parallel to grain	6.0	5.0
B	End distance parallel to grain	5.0	3.0
C	Spacing perpendicular to grain	3.0	2.5
D	Edge distance perp to grain	1.5	1.0

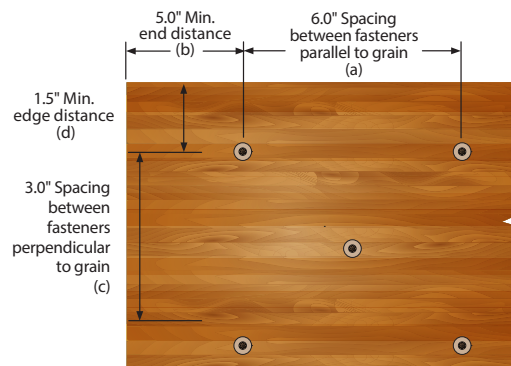

D-Fir Larch Spacing Requirements¹

¹ Additional screws may be staggered diagonally between rows.

MAXIMUM FASTENER SPACING FOR DECK LEDGER TO RIM BOARD 3/8" (in.)

LEDGER SIZE	MODEL	RIM BOARD	SPECIFIED LIVE LOAD psf (kPa)	MAXIMUM DECK JOIST SPAN (ft.) ^(1,2,3,4,5,6)					
				6	8	10	12	14	16
2x	10273	2x SPF	40 (1.9)	17.5	12.5	10.6	16.5	7.5	6.5
		2x SPF	50 (2.4)	14.5	10.5	9.0	7.5	6.5	5.5
		2x SPF	100 (4.8)	8.0	6.0	4.5	4.0	3.5	---

¹ Solid Sawn lumber ledger board shall be a minimum of 2 x 8. Spacings apply to S-P-F, Hem-Fir or D-Fir-L.

² Spacing requirements are based on testing as per ICC-ES and modified to meet the requirements of 12.9.2.1 CSA 086-14 assuming dry service conditions.

³ Tabulated values are based on the listed specified live loads in combination with 10 psi (.50 kPa) specified dead load.

⁴ RSS Screws shall be placed in accordance with screw spacing shown in tables above.

⁵ Factored resistances shown assume the entire threaded portion of the screw is installed into the main member.

⁶ Spacing calculated based on factored resistance shown in tables above.

Factored Resistances (JTS - Joint and gtruss Screw)

FACTORED RESISTANCES FOR D.FIR MEMBERS (LBS)

SIZE			MODEL/ BULB PART NO.	THREADED LENGTH (in)	THREADED LENGTH (mm)	D-FIR LARCH ^(1,2,3,4,5)										0.48	
SHANK DIAMETER	THREAD DIA (in)	LENGTH (in)				FACTORED LATERAL RESISTANCE (Kd=1.00) WOOD SIDE MEMBER THICKNESS (mm & in)											WITHDRAWAL (LBS)
			38.1	50.8	63.5	76.2	88.9	101.6	114.3	127	152.4	203.2					
			1.5	2	2.5	3	3.5	4	4.5	5	6	8					
.173	0.25	3.375	91727	1.375	34.925	311	311	201	---	---	---	---	---	---	---	---	385
		5	91735	1.625	41.275	337	383	397	383	337	230	---	---	---	---	---	455
		6.75	91743	1.5	38.1	337	383	397	397	397	397	397	360	---	---	---	420

¹ See Foot Notes below

FACTORED RESISTANCES FOR S-P-F MEMBERS (LBS)

SIZE			MODEL/ BULB PART NO.	THREADED LENGTH (in)	THREADED LENGTH (mm)	SPRUCE-PINE-FIR ^(1,2,3,4,5)										0.42	
SHANK DIAMETER	THREAD DIA (in)	LENGTH (in)				FACTORED LATERAL RESISTANCE (Kd=1.00) WOOD SIDE MEMBER THICKNESS (mm & in)											WITHDRAWAL (LBS)
			38.1	50.8	63.5	76.2	88.9	101.6	114.3	127	152.4	203.2					
			1.5	2	2.5	3	3.5	4	4.5	5	6	8					
.173	0.25	3.375	91727	1.375	34.925	272	272	176	---	---	---	---	---	---	---	---	304
		5	91735	1.625	41.275	302	342	362	342	302	201	---	---	---	---	---	359
		6.75	91743	1.5	38.1	302	342	362	362	362	362	362	322	---	---	---	332

¹ Factored resistances shown have been developed in accordance with 12.11 CSA 086-14 based on testing per ICC-ES AC233. Apply the adjustment factors Kd, Ksf and Kt as per 15.2.2 where applicable. Do not install in end grain.

² Factored withdrawal resistances shown are only applicable to short term loads as per 12.11.5 CSA 086-14

³ Factored withdrawal resistances shown assume the entire threaded portion of the screw is installed into the main member.

⁴ Minimum spacing, edge and end distances shall be in accordance with 12.9.2.1 CSA 086-14 using the corresponding shank diameter. See table on page G 16.

⁵ Divide table value by 224.8 to convert to kN (1Kn = 224.8 lbs)

Factored Resistances (RSS JTS) continued on next page

RSS™ Rugged Structural Screws

Factored Resistances (RSS JTS) continued from page G 15

STANDARD RSS SCREW (JTS/LPS)

	GEOMETRY	MINIMUM DIMENSIONS (in)	
		D. FIR-L	S-P-F
A	Spacing parallel to grain	5.0	4.0
B	End distance parallel to grain	3.6	3.0
C	Spacing perpendicular to grain	2.5	2.0
D	Edge distance perp to grain	1.5	1.0

¹ Additional screws may be staggered diagonally between rows.

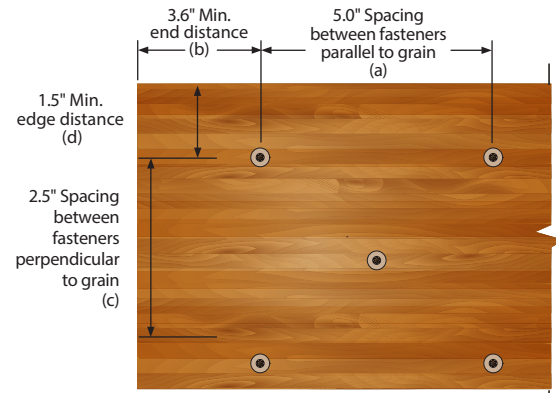

D-Fir Larch Spacing Requirements¹

Factored Resistances (LPS - Panel Screw)

FACTORED RESISTANCES FOR D.FIR MEMBERS (LBS)

SIZE			MODEL/ BULB PART NO.	THREADED LENGTH (in)	THREADED LENGTH (mm)	D-FIR LARCH ^(1,2,3,4,5)										WITHDRAWAL (LBS)
SHANK DIAMETER	THREAD DIA (in)	LENGTH (in)				FACTORED LATERAL REISTANCE (Kd=1.00) WOOD SIDE MEMBER THICKNESS (mm & in)										
			38.1	50.8	63.5	76.2	88.9	101.6	114.3	127	152.4	203.2				
.172	0.25	8	91181	2.875	73.025	309	344	344	344	344	344	344	344	344	---	794

¹ See Foot Notes below

FACTORED RESISTANCES FOR S-P-F MEMBERS (LBS)

SIZE			MODEL/ BULB PART NO.	THREADED LENGTH (in)	THREADED LENGTH (mm)	SPRUCE-PINE-FIR ^(1,2,3,4,5)										WITHDRAWAL (LBS)
SHANK DIAMETER	THREAD DIA (in)	LENGTH (in)				FACTORED LATERAL REISTANCE (Kd=1.00) WOOD SIDE MEMBER THICKNESS (mm & in)										
			38.1	50.8	63.5	76.2	88.9	101.6	114.3	127	152.4	203.2				
.172	0.25	8	91181	2.875	73.025	277	314	314	314	314	314	314	314	314	---	627

¹ Factored resistances shown have been developed in accordance with 12.11 CSA 086-14 based on testing per ICC-ES AC233. Apply the adjustment factors Kd, Ksf and Kt as per 15.2.2 where applicable. Do not install in end grain.

² Factored withdrawal resistances shown are only applicable to short term loads as per 12.11.5 CSA 086-14

³ Factored withdrawal resistances shown assume the entire threaded portion of the screw is installed into the main member.

⁴ Minimum spacing, edge and end distances shall be in accordance with 12.9.2.1 CSA 086-14 using the corresponding shank diameter. See table below.

⁵ Divide table value by 224.8 to convert to kN (1Kn = 224.8 lbs)

STANDARD RSS SCREW (JTS/LPS)

	GEOMETRY	MINIMUM DIMENSIONS (in)	
		D. FIR-L	S-P-F
A	Spacing parallel to grain	5.0	4.0
B	End distance parallel to grain	3.6	3.0
C	Spacing perpendicular to grain	2.5	2.0
D	Edge distance perp to grain	1.5	1.0

¹ Additional screws may be staggered diagonally between rows.

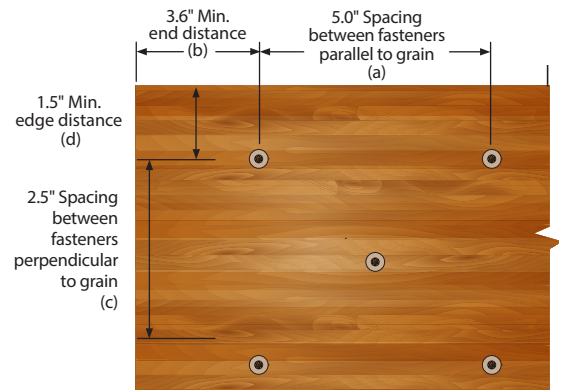

D-Fir Larch Spacing Requirements¹

Factored Resistances (RSS 3/8") continued on next page

Factored Resistances (RSS LTF - Timber Frame Screw)

FACTORED RESISTANCES FOR D.FIR MEMBERS (LBS)

SIZE			MODEL/ BULB PART NO.	THREADED LENGTH (in)	THREADED LENGTH (mm)	D-FIR LARCH ¹										0.48 WITHDRAWL (LBS)
SHANK DIAMETER	THREAD DIA (in)	LENGTH (in)				FACTORED LATERAL REISTANCE (Kd=1.00) WOOD SIDE MEMBER THICKNESS (mm & in)										
						38.1 1.5	50.8 2	63.5 2.5	76.2 3	88.9 3.5	101.6 4	114.3 4.5	127 5	152.4 6	203.2 8	
.220	0.375	8	22300	3.875	98.4	449	2254	551	551	551	551	551	551	507	---	1337
		10	22400	3.875	98.4	449	507	551	551	551	551	551	551	551	507	1337
		12	22500	3.875	98.4	449	507	551	551	551	551	551	551	551	551	1337

¹ See Foot Notes below

FACTORED RESISTANCES FOR S-P-F MEMBERS (LBS)

SIZE			MODEL/ BULB PART NO.	THREADED LENGTH (in)	THREADED LENGTH (mm)	SPRUCE-PINE-FIR ^(1,2,3,4,5)										0.42 WITHDRAWL (LBS)
SHANK DIAMETER	THREAD DIA (in)	LENGTH (in)				FACTORED LATERAL REISTANCE (Kd=1.00) WOOD SIDE MEMBER THICKNESS (mm & in)										
						38.1 1.5	50.8 2	63.5 2.5	76.2 3	88.9 3.5	101.6 4	114.3 4.5	127 5	152.4 6	203.2 8	
.220	0.375	8	22300	3.875	98.4	403	454	502	502	502	502	502	502	454	---	1055
		10	22400	3.875	98.4	403	454	502	502	502	502	502	502	502	454	1055
		12	22500	3.875	98.4	403	454	502	502	502	502	502	502	502	502	1055

¹ Factored resistances shown have been developed in accordance with 12.11 CSA 086-14 based on testing per ICC-ES AC233. Apply the adjustment factors Kd, Ksf and Kt as per 15.2.2 where applicable. Do not install in end grain.

² Factored withdrawal resistances shown are only applicable to short term loads as per 12.11.5 CSA 086-14

³ Factored withdrawal resistances shown assume the entire threaded portion of the screw is installed into the main member.

⁴ Minimum spacing, edge and end distances shall be in accordance with 12.9.2.1 CSA 086-14 using the corresponding shank diameter. See table below.

⁵ Divide table value by 224.8 to convert to kN (1Kn = 224.8 lbs)

STANDARD RSS SCREW (SIZE 3/8" OR LTF)

	GEOMETRY	MINIMUM DIMENSIONS (in)	
		D. FIR-L	S-P-F
A	Spacing parallel to grain	6.0	5.0
B	End distance parallel to grain	5.0	3.0
C	Spacing perpendicular to grain	3.0	2.5
D	Edge distance perp to grain	1.5	1.0

¹ Additional screws may be staggered diagonally between rows.

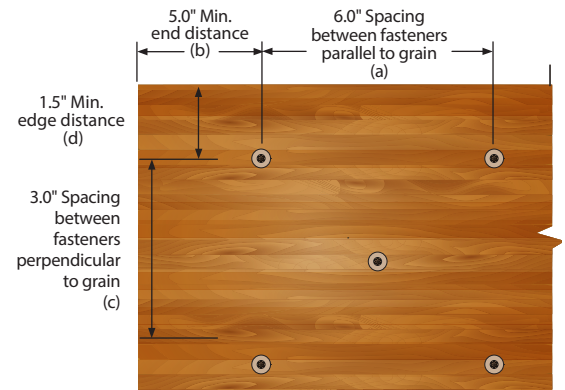

D-Fir Larch Spacing Requirements¹

Kameleon™

**Composite Deck
Screws**

**Heads Blend in
with Decking.
No Mushrooming
Effect**

DESCRIPTION/SUGGESTED SPECIFICATIONS

Composite Deck Screws—

GRK's Kameleon™ screws are an excellent choice for composite and PVC decking applications. The underhead has saw-blade like cutting teeth that cut a perfectly clean hole into the decking.

The Kameleon™ also features five to seven rings that have three indented fibre traps on each ring designed to trap fibres and eliminate the mushroom effect.

ÜberGrade™



The CEE Thread feature enlarges the screw hole allowing the composite decking to settle easily, increases the screw's drawing strength, and reduces the friction on the screw shank, which can result in lowering the overall driving torque.

The Kameleon™ is also available in many different colours including: Grey, Sand, Tan, Brown, and Redwood. Plus, Trex Select® approved colours Pebble Grey, Saddle, Woodland Brown and Madeira.

ADVANTAGES

- **Recessed Star Drive:** Zero Stripping, with 6 points of contact.
- **CEE Thread:** Enlarges hole to reduce splitting.
- **W-Cut™:** Low torque, smoother drive.
- **Zip-Tip™:** No pre-drilling, faster penetration.
- **Fibre Trapping Rings:** are designed to prevent mushrooming and dimpling.
- **Cutting Pockets:** provide a clean hole, reduces splitting, and bore with precision.
- **ESR-3201 Approved** for structural application.
- **Case Hardened Steel:** for high tensile, torque and shear strength.
- **Climatek™ Coating** is AC257 code approved for use in treated lumber.
- For interior/exterior use in; both composite and PVC decking.

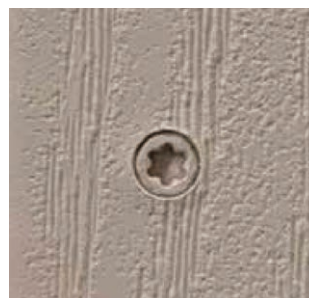
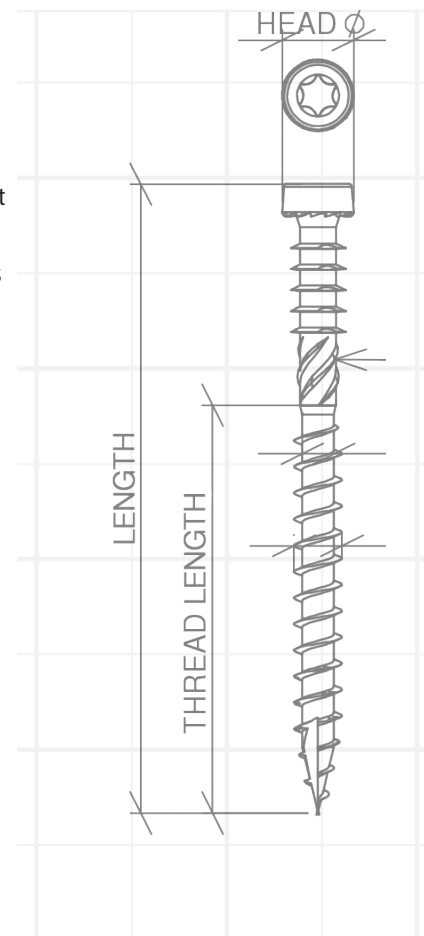

APPROVALS/LISTING



Kameleon™ Composite Deck Screws

SELECTION CHART



T-20

	U.S. (STD.) SIZE (DIA. X LENGTH)	METRIC SIZE (DIA. X LENGTH)	BULK PART NO.	BULK BOX QTY.	PRO-PAK PART NO.	PRO-PAK PAIL QTY.	HANDY-PAK PART NO.	HANDY-PAK CTN. SIZE/QTY.
Grey	#9 x 2-1/2"	4.5 x 63	65151	2,900	66151	510	67151	M/100
Sand	#9 x 2-1/2"	4.5 x 63	65154	2,900	66154	510		
Tan	#9 x 2-1/2"	4.5 x 63	65155	2,900	66155	510	67155	M/100
Brown	#9 x 2-1/2"	4.5 x 63	65158	2,900	66158	510	67158	M/100
Redwood	#9 x 2-1/2"	4.5 x 63	65159	2,900	66159	510	67159	M/100
Pebble Grey	#9 x 2-1/2"	4.5 x 63			66160	510		
Saddle	#9 x 2-1/2"	4.5 x 63			66161	510		
Woodland Brown	#9 x 2-1/2"	4.5 x 63			66162	510		
Grey	#9 x 2-3/4"	4.5 x 70	65171	2,000	66171	420		
Tan	#9 x 2-3/4"	4.5 x 70	65175	2,000	66175	420		
Brown	#9 x 2-3/4"	4.5 x 70	65178	2,000	66178	420		
Redwood	#9 x 2-3/4"	4.5 x 70	65179	2,000	66179	420		
Pebble Grey	#9 x 3"	4.5 x 76			66190	375		
Saddle	#9 x 3"	4.5 x 76			66191	375		
Woodland Brown	#9 x 3"	4.5 x 76			66192	375		
Madeira	#9 x 3"	4.5 x 76			66193	375		

TREX Select® Kameleon™ Composite Deck Screws are available in 2-1/2" to 3" 5 lb. Pro-Paks. Enough to cover 150 square feet. Pro-Paks are available in Pebble Grey, Saddle, Woodland Brown and Madeira.



NOTE: Pro-Paks need to be ordered in multiples of two. 2" bit included in Pro-Paks, 1" bits in Handy-Paks.



Call our toll free number 800-387-9692 or visit www.itwconstruction.ca for general information. Visit GRK Fasteners web site www.grkfasteners.com for the most current product and technical information.



Fin/Trim™

*Finishing Trim
Head Screws*

*Smallest Head on
the Market for a
Clean Finish*



APPROVALS/LISTING



DESCRIPTION/SUGGESTED SPECIFICATIONS

Finishing Trim Head Screws—

GRK's Trim™ Head screws are an excellent choice for most fine carpentry applications, as well as window extension jambs and more. Our Trim™ Head screws have the smallest screw head available; with screw lengths from 1-1/4" (30 mm) to 5" (125 mm).

ÜberGrade™

Most material splitting is prevented because of the Trim™ Head screw's exceptionally small head and the W-Cut thread design.



Fin/Trim™ screws are also available in white Climatek™ coated finish to blend in with white wooden trim boards.

ADVANTAGES

- **Recessed Star Drive:** Zero Stripping, with 6 points of contact.
- **Trim Head:** for a clean finished look.
- **W-Cut™:** Low torque, smoother drive.
- **Zip-Tip™:** No pre-drilling, faster penetration.
- **ESR-3201 Approved** for structural application.
- **Case Hardened Steel:** for high tensile, torque and shear strength.
- **Climatek™ Coating is AC257** code approved for use in treated lumber.
- For interior/exterior use.
- Available in **Climatek™** or white powder coated finish.
- Also available in **PHEINOX™** 305 grade Stainless Steel.

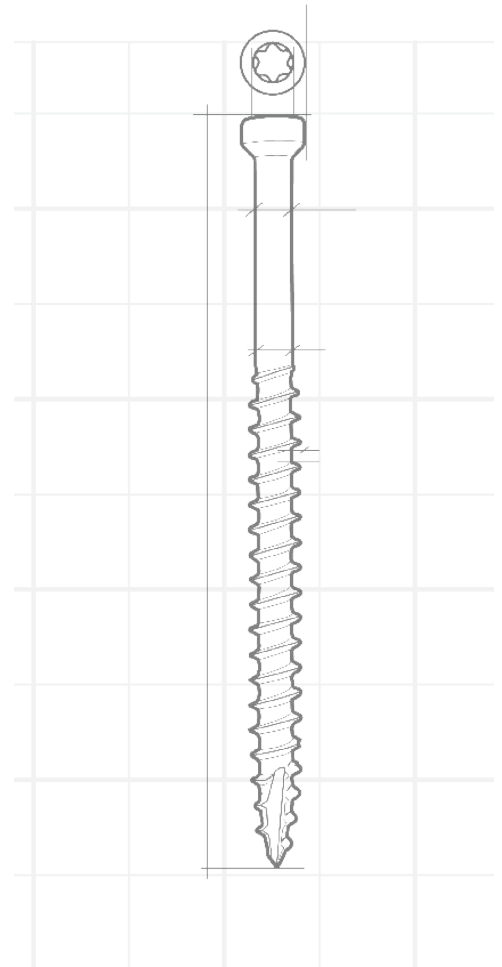

SELECTION CHART



T-10



T-15



T-10

U.S. (STD.) SIZE (DIA. X LENGTH)	METRIC SIZE (DIA. X LENGTH)	BULK PART NO.	BULK BOX QTY.	PRO-PAK PART NO.	PRO-PAK PAIL QTY.	HANDY-PAK PART NO.	HANDY-PAK CTN. SIZE/QTY.
#8 x 1-1/4"	4.0 x 30					17720	S/100
#8 x 1-1/2"	4.0 x 40	15724	6,500	16724	915	17724	S/100
#8 x 2"	4.0 x 50	15728	4,500	16728	725	17728	S/100
#8 x 2-1/2"	4.0 x 63	15730	3,500	16730	605	17730	S/100
#8 x 2-3/4"	4.0 x 70			16732	544	17732	S/100
#8 x 3-1/8"	4.0 x 80	15734	2,500	16734	514	17734	M/100
#9 x 2-1/2"	4.5 x 63					17752	M/100
#9 x 3-1/8"	4.5 x 80	15756	1,900			17756	M/100
#9 x 4"	4.5 x 100	15760	1,000			17760	M/100
#9 x 5"	4.5 x 125	15766	800			17766	M/100
WHITE FIN/TRIM™							
#8 x 2-1/2"	4.0 x 63	15830	3,500			17830	S/100

**Excellent for all of
your trimwork and fine
carpentry finishing.**



Some sizes available in **PHEINOX™** hardened Stainless Steel; refer to pages 26-27.

NOTE: Pro-Paks need to be ordered in multiples of two. 2" bit included in Pro-Paks, 1" bits in Handy-Paks.

**Composite Exterior
Trim Screws**
**Reverse Thread
Design Prevents
Mushrooming**



APPROVALS/LISTING



DESCRIPTION/SUGGESTED SPECIFICATIONS

Exterior Trim Screws—

GRK has modified its innovative FIN/Trim™ Head screw to include reverse threading under the head of the fastener. This technology makes the RT Composite™ Trim Screw ideal for use in composite and cellular PVC trim.

ÜberGrade™



Based on extensive tests, GRK has found that the reverse thread helps the screw head disappear beneath the surface of the classic wood composite material, reducing or eliminating the dimple that sometimes appears when using the FIN/Trim™ screw.

The reverse thread feature is available in RT Composite™ screws from 2" to 3-1/8" in length in both regular Climatek™ coating and in white Climatek™ coated finish to blend in with popular white exterior composite and cellular PVC trim.

ADVANTAGES

- **Recessed Star Drive:** Zero Stripping, with 6 points of contact.
- **Reverse Threads** eliminate mushrooming.
- **Trim Head:** for a clean finished look.
- **W-Cut™:** Low torque, smoother drive.
- **Zip-Tip™:** No pre-drilling, faster penetration.
- **ESR-3201 Approved** for structural application.
- **Case Hardened Steel:** for high tensile, torque and shear strength.
- **Climatek™ Coating is AC257** code approved for use in treated lumber.
- For interior/exterior use in; exterior PVC trim (Azek, Kleer, Koma), no pre-drilling is necessary. Climatek™ coated screws work well with CAMO system.
- Available in **Climatek™** or white powder coated finish.
- Also available in **PHEINOX™** 305 grade Stainless Steel.

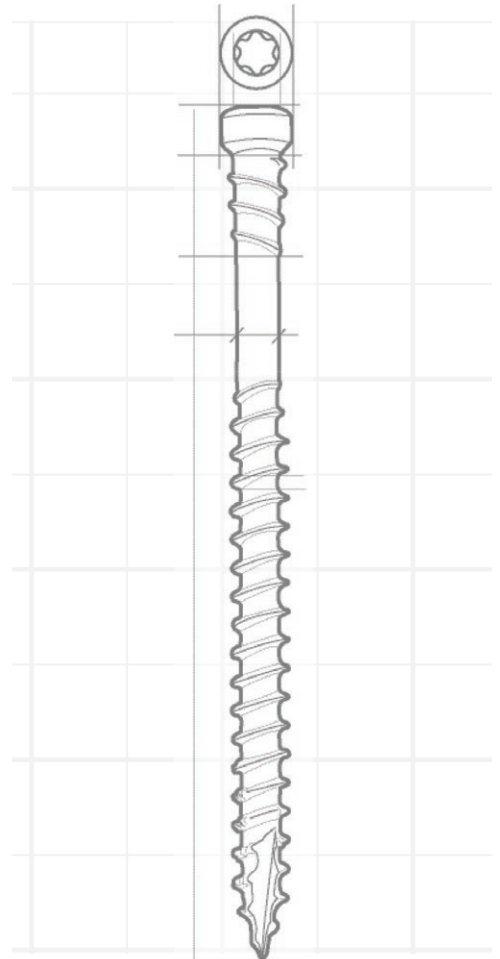

RT Composite™ Exterior Trim Screws

SELECTION CHART



T-10



T-15



T-10

U.S. (STD.) SIZE (DIA. X LENGTH)	METRIC SIZE (DIA. X LENGTH)	BULK PART NO.	BULK BOX QTY.	PRO-PAK PART NO.	PRO-PAK PAIL QTY.	HANDY-PAK PART NO.	HANDY-PAK CTN. SIZE/QTY.
#8 x 2"	4.0 x 50	15077	4,500	16077	725	17077	S/100
#8 x 2-1/2"	4.0 x 63	15079	3,500	16079	605	17079	S/100
#8 x 2-3/4"	4.0 x 70	15081	3,000	16081	544		
#8 x 3-1/8"	4.0 x 80	15083	2,500	16083	514		
#9 x 2-1/2"	4.5 x 63	15101	2,900	16101	408		
#9 x 3-1/8"	4.5 x 80	15105	1,900	16105	348		
WHITE RT COMPOSITE™							
#8 x 2-1/2"	4.0 x 63	15630	3,500			17630	S/100
#8 x 2-3/4"	4.0 x 70			16632	450		

**Supreme Drawing Power
is perfect for trimwork
and deck construction.**

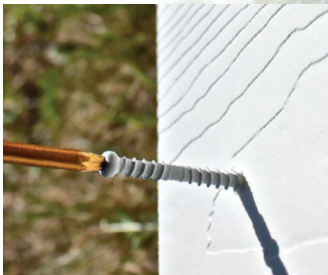

Some sizes available in **PHEINOX™** hardened Stainless Steel; refer to pages 26-27.

NOTE: Pro-Paks need to be ordered in multiples of two. 2" bit included in Pro-Paks, 1" bits in Handy-Paks.



Call our toll free number 800-387-9692 or visit www.itwconstruction.ca for general information.
Visit GRK Fasteners web site www.grkfasteners.com for the most current product and technical information.



Low Profile™

*Low Profile Cabinet™ Screws
Built-in Washer Head Presses Flush Against any Material*



APPROVALS/LISTING



DESCRIPTION/SUGGESTED SPECIFICATIONS

Cabinet Screws—

GRK's Cabinet™ screws are designed specifically for use in cabinet construction and installation. Cabinet™ screws are manufactured in a #8 gauge (4 mm) diameter for universal size convenience.

These screws are thin enough to prevent most material splitting, while providing sufficient strength to guarantee a secure installation. The washer head design presses flush against any material surface.

ÜberGrade™

Builders have discovered that short Cabinet™ screws can sometimes be used in vinyl siding installation, which makes this fastener ideal for both interior and exterior applications.



The Cabinet screw can also be used for light duty framing applications where a smaller diameter shank is necessary, yet a need exists for drawing power delivered by the washer head.

ADVANTAGES

- **Recessed Star Drive:** Zero Stripping, with 6 points of contact.
- **Washer Head:** Creates a flush, clean hold for a strong and secure installation.
- **W-Cut™:** Low torque, smoother drive.
- **Zip-Tip™:** No pre-drilling, faster penetration.
- **Case Hardened Steel:** for high tensile, torque and shear strength.
- **Climatek™ Coating is AC257** code approved for use in treated lumber.
- For interior/exterior use.

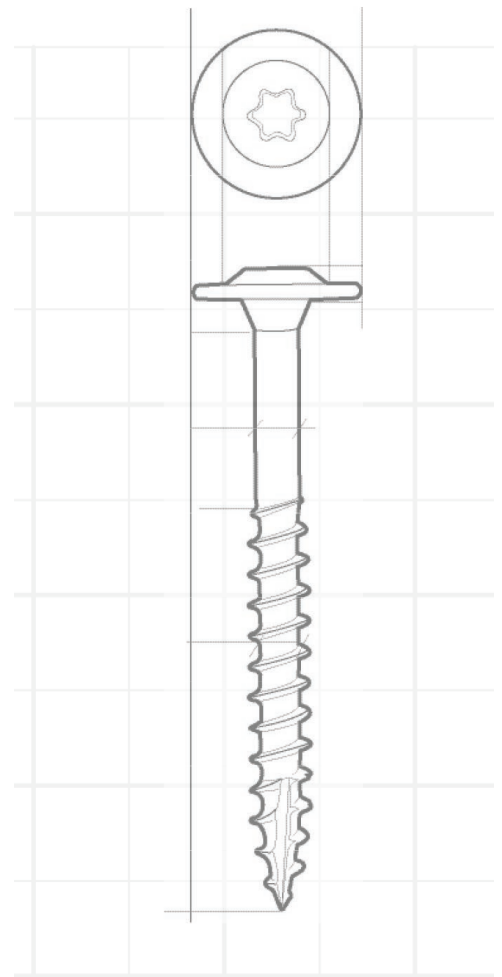

SELECTION CHART



T-15

U.S. (STD.) SIZE (DIA. X LENGTH)	METRIC SIZE (DIA. X LENGTH)	BULK PART NO.	BULK BOX QTY.	PRO-PAK PART NO.	PRO-PAK PAIL QTY.	HANDY-PAK PART NO.	HANDY-PAK CTN. SIZE/QTY.
#8 x 1-1/4"	4.0 x 30	10069	4,000			12069	S/100
#8 x 1-1/2"	4.0 x 40					12073	M/100
#8 x 1-3/4"	4.0 x 45	10075	2,000			12075	M/100
#8 x 2"	4.0 x 50	10077	2,000	11077	650	12077	M/100
#8 x 2-1/2"	4.0 x 63	10079	1,500			12079	M/100
#8 x 3-1/8"	4.0 x 80	10083	1,000	11083	400		

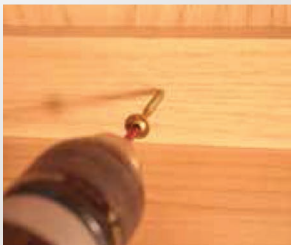

Ideal for Cabinets...and so much more. Also excellent for a variety of interior or exterior jobs.

Some sizes available in **PHEINOX™** hardened Stainless Steel; refer to pages 26-27.

NOTE: Pro-Paks need to be ordered in multiples of two. 2" bit included in Pro-Paks, 1" bits in Handy-Paks.



Call our toll free number 800-387-9692 or visit www.itwconstruction.ca for general information. Visit GRK Fasteners web site www.grkfasteners.com for the most current product and technical information.



Pheinox™

**Stainless Steel
Screws**

**Maximum
Corrosion
Protection
for Harsh
Environments**



APPROVALS/LISTING



DESCRIPTION/SUGGESTED SPECIFICATIONS

Pheinox™ Stainless Steel Screws—

PHEINOX™ stainless steel screws are made from only the best grade of stainless steel wire, 305. The unique characteristics of the PHEINOX™ wire give our stainless steel screws unmatched performance, by maximizing both torque and increasing bending strength.

ÜberGrade™

GRK's patented R4™, RSS™, Fin/Trim™, and RT Composite™ screws are available in PHEINOX™ stainless steel. Use PHEINOX™ screws from GRK for projects that should last a lifetime.



GRK recommends the use of its PHEINOX™ stainless steel fasteners in tropical wood, cedar wood, pool, hot tub, sauna and seaside applications, as well as deck applications in areas with large daily temperature variances. The ultimate finish for superior all weather corrosion protection.

ADVANTAGES

- **305 grade stainless steel** for a superior combination of strength and corrosion resistance.
- **ESR-2442 Approved** for structural application.
- **Hardened Stainless Steel** finish provides extraordinary anti-corrosion protection.
- **CEE Thread™** – enlarges hole to reduce splitting. Increases drawing strength.
- **W-Cut™ Thread Design** tiny saw blades reduce torque by cutting through the material.
- **ZIP-TIP™** for easy starts and no pre-drilling.
- Available in a wide range of sizes and types.
- For use in exterior construction in coastal areas and below ground applications and use including pools, docks and boardwalks.

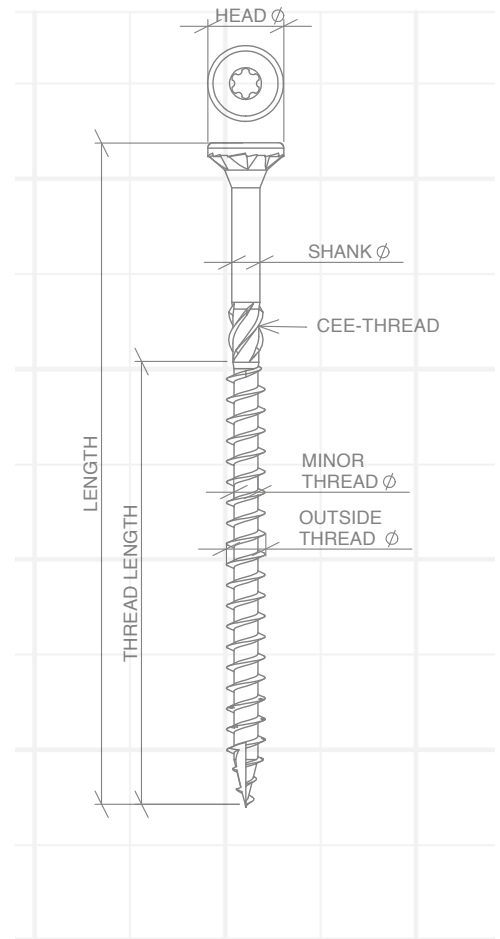

SELECTION CHART



T-25



T-30



T-10



T-10



T-15

U.S. (STD.) SIZE (DIA. X LENGTH)	METRIC SIZE (DIA. X LENGTH)	BULK PART NO.	BULK BOX QTY.	PRO-PAK PART NO.	PRO-PAK PAIL QTY.	HANDY-PAK PART NO.	HANDY-PAK CTN. SIZE/QTY.
R4™ SCREWS							
#9 x 2"	4.5 x 50	25099	4,000	26099	609	27099	M/100
#10 x 2-1/2"	5.0 x 63	25133	2,500	26133	425	27133	M/100
#10 x 2-3/4"	5.0 x 70	25135	2,000	26135	350		
#10 x 3-1/8"	5.0 x 80	25137	1,500	26137	305	27137	M/100
#10 x 4"	5.0 x 100	25141	1,000				
RSS™ SCREWS							
5/16" x 3-1/8"	7.0 x 80					32221	12/100
5/16" x 4"	7.0 x 100					32225	12/100
5/16" x 6"	7.0 x 150					32235	9/50
RT COMPOSITE™ TRIM SCREWS							
#8 x 2-1/2"	4.0 x 63	35079	3,500				
#8 x 3-1/8"	4.0 x 80			36083	385		
FIN / TRIM™ SCREWS							
#8 x 1-1/2"	4.0 x 40	35724	6,500	36724	800	37724	S/100
#8 x 2"	4.0 x 50	35728	4,500	36728	600	37728	S/100
#8 x 2-1/2"	4.0 x 63	35730	3,500	36730	560	37730	S/100
#8 x 2-3/4"	4.0 x 70			36732	420		
#8 x 3-1/8"	4.0 x 80			36734	385		
#9 x 2-1/2"	4.5 x 63			36752	365		

2" bit included in Pro-Paks, 1" bits in Handy-Paks.

Top Star™

Adjustable Shim Screws

For Plumb Installation of Wooden Doors and Windows. No More Shims!



DESCRIPTION/SUGGESTED SPECIFICATIONS

Adjustable Shim Screws—

GRK's adjustable Top Star™ shim screw, is in fact a screw within a screw that allows you to install wooden doors or windows without the use of shims.

ÜberGrade™

The quick and easy system reduces labour and allows for hassle free adjustment to ensure plumb installation.



Door stop or cover caps will hide hole

Our product is suited to meet the needs of both professional contractors and weekend warriors making the job easier for one person.

Fine adjustments are as simple as the turn of a screw, even after years of use and settling.

ADVANTAGES

- **Recessed Star Drive:** Zero Stripping, with 6 points of contact.
- **4-point 3/8" diameter Threaded Sleeve** provides a secure hold on your wooden frame.
- **Micro-Adjustments** allow for an absolutely plumb installation.
- Use with GRK's **Top Star™ Crown** and **T-15 Star bit system**.
- **White Zinc Plated** finish for lasting durability.
- **For Shim Free installation** of wooden doors, windows, insulation, paneling, built-in wall units and cabinets.

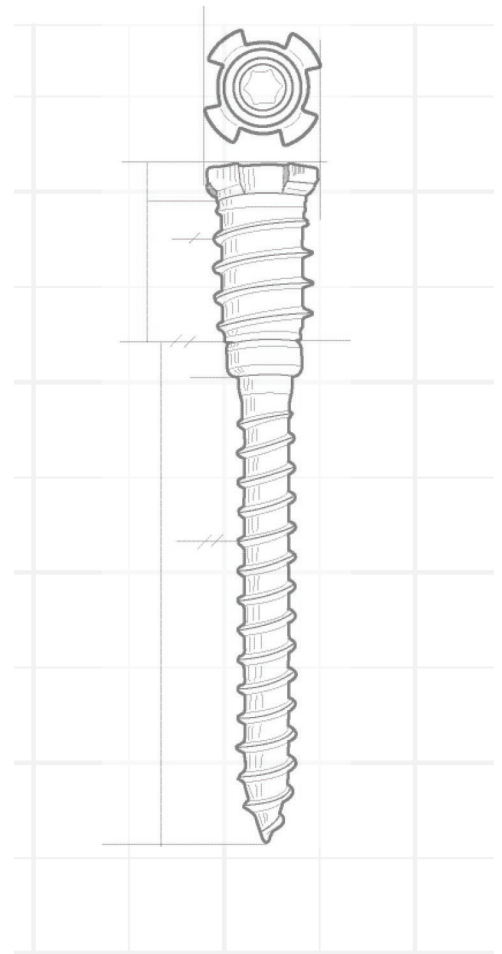

SELECTION CHART

U.S. (STD.) SIZE (DIA. X LENGTH)	METRIC SIZE (DIA. X LENGTH)	BULK PART NO.	BULK BOX QTY.	PRO-PAK PART NO.	PRO-PAK PAIL QTY.
3/8" x 2-1/2"	6.0 x 63	20157	100	24050	6
3/8" x 3-1/8"	6.0 x 80	20161	100	124100	6
CROWN / BIT					
Includes: (1) Crown / Bit with each				86465	1



The Bit drives the Top Star™ into the material when the Crown and Bit are combined. Using the Bit without the Crown adjusts the distance.

The Threaded Sleeve moves independently from the Top Star™ unless locked by the Crown. When locked, the Top Star™ gets driven into the material. Unlocked, the installed Top Star™ is ready for levelling.

The Complete Top Star™ System Includes:

BIT

CROWN

THREADED SLEEVE

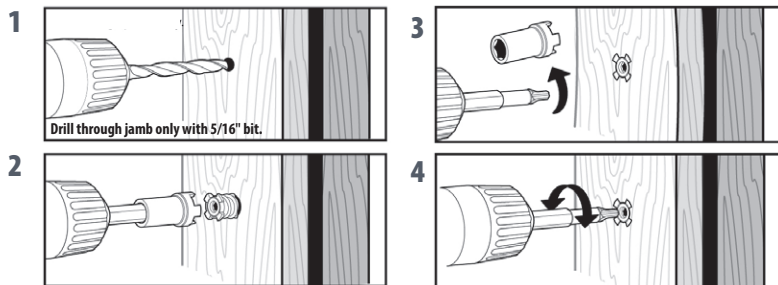

NOTE: Crown and Star bit system included in each bulk box. 5/16" drill bit not included.



**Vinyl Window
Screws
Install
Replacement
Windows Without
the Use of Shims**



APPROVALS/LISTING



DESCRIPTION/SUGGESTED SPECIFICATIONS

Vinyl Window Screws—

GRK's VWS™ Vinyl Window Screws are designed to quickly adjust windows to plumb alignments without tedious measuring. The patented Vinyl Window Screw makes setting vinyl windows a breeze.

ÜberGrade™

By catching the window frame between the screw head and the screw's secondary shoulder, the window position can be quickly and easily adjusted.



Our product is perfectly suited to meet the needs of both the professional and do-it-yourself installers. Simply pre-drill the first layer, insert screw, lock collar and adjust... it's just that easy.

ADVANTAGES

- **Patented Washer Head** creates a tight draw.
- **Climatek™ Coating** is AC257 code approved for use in treated lumber.
- **Innovative Edge Design** under the head to capture the vinyl strap at penetration time.
- **W-Cut™ Thread Design** tiny saw blades reduce torque by cutting through the material.
- **ZIP-TIP™** for easy starts and no pre-drilling.

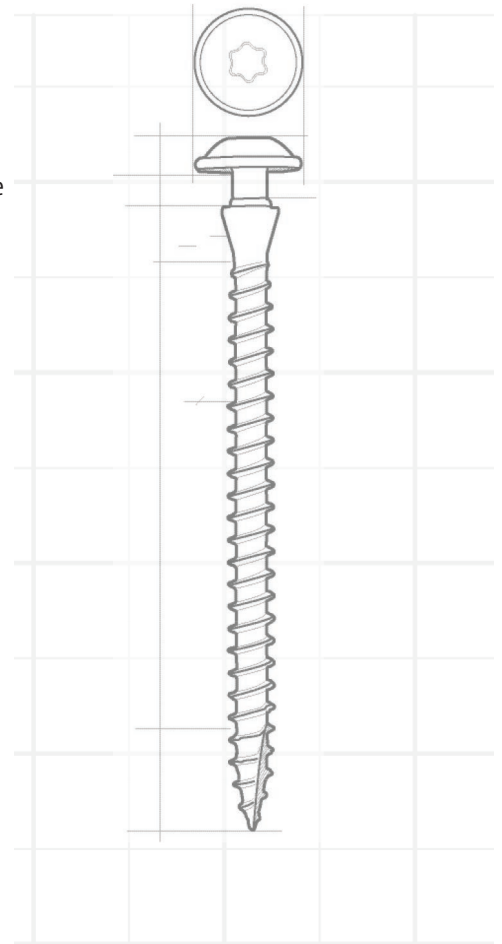

SELECTION CHART



T-15

U.S. (STD.) SIZE (DIA. X LENGTH)	METRIC SIZE (DIA. X LENGTH)	BULK PART NO.	BULK BOX QTY.	PRO-PAK PART NO.	PRO-PAK PAIL QTY.	HANDY-PAK PART NO.	HANDY-PAK CTN. SIZE/QTY.
		Blister-Pak Part No.		Blister-Pak Qty/per pack			
#8 x 2"	4.0 x 50		53077				6
#8 x 2-1/2"	4.0 x 63		53079				6

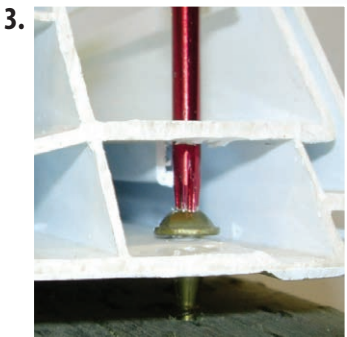
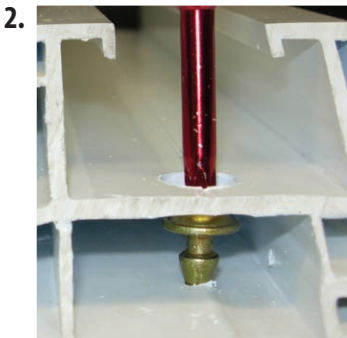
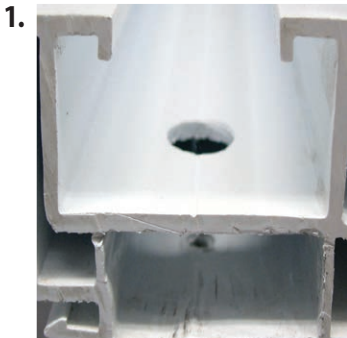

1. PRE-DRILL WINDOW FRAME.
2. INSERT SCREW.
3. LOCK COLLAR & ADJUST.

NOTE: Pro-Paks need to be ordered in multiples of two.
2" bit included in Pro-Paks, 1" bits in Handy-Paks.



Call our toll free number 800-387-9692 or visit www.itwconstruction.ca for general information.
Visit GRK Fasteners web site www.grkfasteners.com for the most current product and technical information.



Caliburn™

Concrete Screws

Heavy Duty Concrete and Masonry Fastener



APPROVALS/LISTING



DESCRIPTION/SUGGESTED SPECIFICATIONS

Concrete Screws—

Caliburn™ Concrete screws are professionally engineered fasteners with a patented thread design for ease of driving the screw in concrete and similar applications.

Available in three different head designs for multiple applications. Caliburn™, Caliburn™ PH and Caliburn™ XL are Climatek™ coated for high corrosion resistance.

ÜberGrade™



Caliburn's uncompromised draw and pullout strength make it possible to be used in jobs which previously required an anchor. The screws aggressive thread design afford it the ability to be removed and reinserted into the same pilot hole numerous times—without the concern of the fastener breaking or the threads wearing.

ADVANTAGES

- **Recessed Star Drive:** Zero Stripping, with 6 points of contact.
- **Aggressive Heavy duty threads** lock into concrete and can be removed and reinserted without screw damage.
- **Countersinking Bugle Head** locks wood to concrete for complete installation and effective anchoring.
- **Caliburn™ PH** pan head, which is ideal for an exposed finished look including installation of electrical boxes.
- **Caliburn™ XL** washer head design for superior holding power. The Caliburn™XL is ESR code approved under ICC Report ESR-3251.
- **Climatek™ Coating** is AC257 code approved for use in treated lumber.
- Ideal for use in anchoring to concrete or wood to concrete applications including basement framing and sheds.

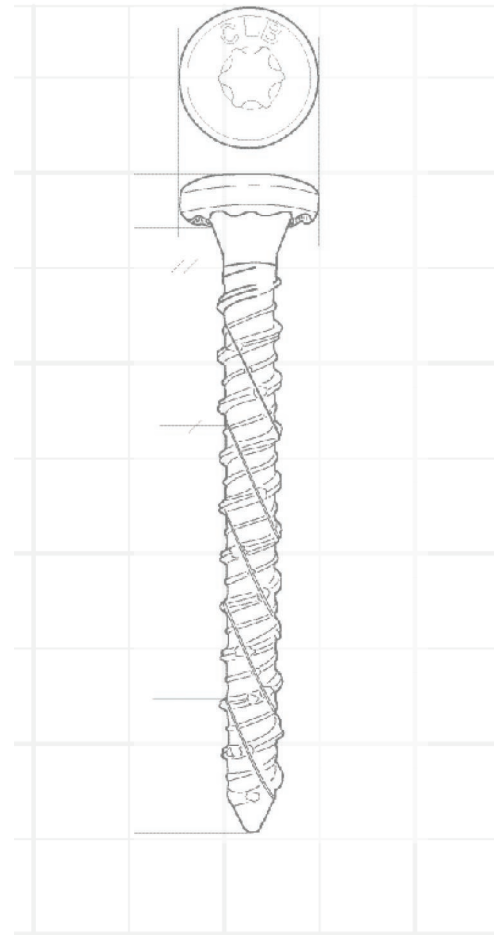

SELECTION CHART



T-30



T-30



T-40

U.S. (STD.) SIZE (DIA. X LENGTH)	METRIC SIZE (DIA. X LENGTH)	BULK PART NO.	BULK BOX QTY.	PRO-PAK PART NO.	PRO-PAK PAIL QTY.	HANDY-PAK PART NO.	HANDY-PAK CTN. SIZE/QTY.
1/4" x 1-3/4"	6.0 x 45					57153	M/50
1/4" x 2-1/4"	6.0 x 55					57156	M/50
1/4" x 2-3/4"	6.0 x 70	55159	1,000			57159	M/50
1/4" x 3-1/2"	6.0 x 90	55163	800			57163	M/50
1/4" x 5"	6.0 x 125					57171	M/50
CALIBURN™ PH							
1/4" x 1-3/4"	6.0 x 45					57828	M/50
1/4" x 2-1/4"	6.0 x 55					57831	M/50
CALIBURN™ XL							
19/64" x 2-3/4"	7.5 x 70					57774	M/25
19/64" x 3-1/2"	7.5 x 90	55778	400			57778	M/25
19/64" x 5"	7.5 x 125	55785	300			57785	M/25



Great for a wide variety of indoor / outdoor home renovation projects

2" bit included in Pro-Paks,
1" bits in Handy-Paks.

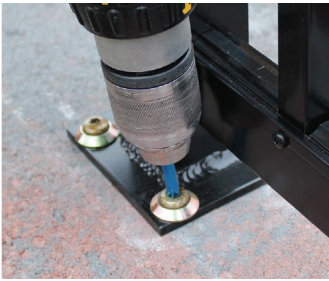



Star Drive Bits, Crown/Bit and Magnetic Bit Holder



BIT SIZE	BIT COLOUR	FITS	BULK PART NO.	BULK BOX QTY.	CARDED PART NO.	CARDED QTY/PER PACK
T-10 1"	yellow	Trim™ Head #8	86417	50		
T-10 2"	yellow		86419	25	87419	2
T-15 1"	red	R4™ Screw #6 & 8 Trim™ Head #9 Cabinet™ Screw Vinyl Window #8	86425	50		
T-15 2"	red				87427	2
T-20 1"	purple	Kameleon™ Screws	86433	50		
T-20 2"	purple				87435	2
T-25 1"	green	R4™ #9,10 & 12, Caliburn™, Caliburn PH™, RSS™ #10 & 1/4" MSS™ #9	86441	50		
T-25 2"	green		86443	25	87443	2
T-30 1"	black	RSS™ Structural Screw 5/16" & 3/8", Caliburn™ & Caliburn PH™	86449	50		
T-30 2"	black		86451	25	87451	2
T-40 1"	blue	Caliburn XL™ Screws RSS™ Structural Screw 3/8"	86457	50		
T-40 2"	blue		86459	25	87459	2
CROWN/BIT						
		TOP STAR™			86465	1

High Impact Merchandisers Designed to Drive Sales

Displays are free with qualifying order.

Universal Display:

Ideal for end-cap with large selection of GRK product.



PERFORMANCE TABLES

TABLE 1: RSS™ FASTENER SPECIFICATIONS

FASTENER DESIGNATION	OVERALL LENGTH ¹ (INCHES)	LENGTH OF THREAD ² (INCHES)	MINOR THREAD DIAMETER ³ (INCHES)	SHANK DIAMETER ³ (INCHES)	OUTSIDE THREAD DIAMETER ³ (INCHES)	ALLOWABLE STEEL STRENGTH			
						BENDING YIELD STRENGTH ⁴ F _{YB} (PSI)	TENSILE (PSI) [POUNDS]	SHEAR (PSI) [POUNDS]	
RSS	1/4 x 2-1/2"	2-3/8	1-1/2	0.150	0.169	0.239	170,427	188,301 [3,336]	127,792 [2,264]
	1/4 x 2-3/4"	2-3/4	1-3/4						
	1/4 x 3-1/8"	3-1/8	2						
	1/4 x 3-1/2"	3-1/2	2-3/8						
	5/16 x 2-1/2"	2-3/8	1-1/2	0.174	0.199	0.280	190,920	178,051 [4,247]	123,592 [2,948]
	5/16 x 2-3/4"	2-3/4	1-3/4						
	5/16 x 3-1/8"	3-1/8	2-1/8						
	5/16 x 3-1/2"	3-1/2	2-1/2						
	5/16 x 4"	3-7/8	2-3/4						
	5/16 x 5-1/8"	5	3-1/2						
	5/16 x 6"	5-7/8	3-7/8						
	3/8 x 3-1/8"	3-1/8	2-1/8						
	3/8 x 4"	3-7/8	2-3/4						
	3/8 x 5-1/8"	5-1/8	3-1/2						
	3/8 x 6"	5-7/8	4						
	3/8 x 7-1/4"	7	4-1/2						
	3/8 x 8"	7-7/8	4-3/8						
	3/8 x 10"	9-3/4	5						
3/8 x 12"	11-7/8	5-7/8							
3/8 x 14-1/8"	14-1/8	5-7/8							
3/8 x 16"	15-5/8	5-3/4							
LPS	1/4 x 8"	7-7/8	2-7/8	0.152	0.172	0.238	172,620	172,950 [3,155]	109,635 [2,000]
LFT	3/8 x 8"	7-7/8	3-7/8	0.191	0.220	0.310	167,580	179,390 [5,144]	114,525 [3,284]
	3/8 x 10"	9-7/8	3-7/8						
	3/8 x 12"	11-3/4	3-7/8						
	3/8 x 15"	14-3/4	3-7/8						
	3/8 x 18"	18	3-7/8						
	3/8 x 20"	19-5/8	3-7/8						
PHENOX	1/4 x 2-1/2"	2-3/8	1-1/2	0.152	0.170	0.237	111,460	103,799 [1,886]	90,260 [1,640]
	1/4 x 3-1/8"	3-1/8	2						
	5/16 x 3-1/8"	3-1/8	2-1/8	0.171	0.195	0.276	118,360	104,767 [2,419]	86,880 [2,006]
	5/16 x 4"	3-7/8	2-1/2						
	5/16 x 6"	5-7/8	3-7/8						
JTS	1/4 x 3-3/8"	3-3/8	1-3/8	0.153	0.173	0.240	226,373	180,999 [3,312]	126,131 [2,308]
	1/4 x 5"	5	1-5/8						
	1/4 x 6-3/4"	6-3/4	1-1/2						

for S1: 1 inch = 25.4 mm; 1 psi = 6.9 kPa.

ULTIMATE LOAD VALUES TENSILE AND SHEAR

¹ Overall length of fastener is measured from the underside of the head to bottom of the tip. See Figure 1.

² Length of thread includes tip. See detailed illustration, Figure 1.

³ Minor thread, shank and outside thread diameters are shown in table without manufacturing tolerances.

⁴ Bending yield strength determined in accordance with ASTM D 1575 using the minor thread diameter.

PERFORMANCE TABLES

TABLE 2: RSS™ ULTIMATE WITHDRAWAL VALUES (W)¹
[WITHDRAWAL VALUES (W) ARE IN POUNDS PER INCH OF THREAD PENETRATION INTO SIDE GRAIN OF MAIN MEMBER]

FASTENER DESIGNATION AND DIAMETER Ø		WITHDRAWAL, W (LBS./IN.) FOR SPECIFIC GRAVITIES OF:	
		0.55	0.42
RSS	Ø 1/4	932	756
	Ø 5/16	1,136	824
	Ø 3/8	1,293	898
LPS	Ø 1/4	1,006	641
LTF	Ø 3/8	1,082	816
PHE	Ø 1/4	936	674
	Ø 5/16	1,012	682
JTS	Ø 1/4	954	760

for S1: 1 inch = 25.4 mm

¹ Fastener withdrawal was tested in accordance with ASTM D 1761.

² Withdrawal values (W) shall be multiplied by the length of thread penetration in the main member (including tip).

TABLE 3: RSS™ ULTIMATE PULL-THROUGH VALUES (P)¹
[PULL-THROUGH VALUES (P) ARE IN POUNDS PER INCH OF SIDE MEMBER THICKNESS]

FASTENER DESIGNATION AND DIAMETER Ø		PULL-THROUGH, P (LBS./IN.) FOR SPECIFIC GRAVITIES OF:	
		0.55	0.42
RSS	Ø 1/4	1,840	933
	Ø 5/16	2,697	1,255
	Ø 3/8	2,332	1,215
LPS	Ø 1/4	2,643	858
LTF	Ø 3/8	2,493	1,263
PHE	Ø 1/4	2,085	1,027
	Ø 5/16	1,702	1,243
JTS	Ø 1/4	2,443	970

for S1: 1 inch = 25.4 mm

¹ Fastener pull-through testing was performed in accordance with ASTM D 1037 with 3/4" thick side members.

These figures are only offered as a guide and are not reduced by any safety factor. For safety factor requirements in your area, contact your local building official, architect or engineer.

PERFORMANCE TABLES

TABLE 4: RSS™ ULTIMATE LATERAL VALUES (Z) FOR SINGLE SHEAR (TWO-MEMBER) CONNECTIONS¹
[FOR SAWN LUMBER OR SCL WITH BOTH MEMBERS OF IDENTICAL SPECIFIC GRAVITY]

FASTENER DESIGNATION	SIDE MEMBER THICKNESS T_s (INCHES):	FASTENER PENETRATION P (INCHES)	ULTIMATE LATERAL VALUE, Z (POUNDS) FOR SPECIFIC GRAVITIES OF:				
			0.55		0.42		
			PARALLEL TO GRAIN $Z_{ }$	PERPENDICULAR TO GRAIN, Z_{\perp}	PARALLEL TO GRAIN $Z_{ }$	PERPENDICULAR TO GRAIN, Z_{\perp}	
RSS	1/4 x 2-1/2"	3/4	1-5/8	876	875	767	685
	1/4 x 2-3/4"	3/4	2				
	1/4 x 3-1/8"	3/4	2-3/8				
	1/4 x 3-1/2"	3/4	2-3/4				
	5/16 x 2-1/2"	3/4	1-5/8	1,068	916	903	765
	5/16 x 2-3/4"	3/4	2	1,088	890	840	663
	5/16 x 3-1/8"	3/4	2-3/8				
	5/16 x 3-1/2"	3/4	2-3/4				
	5/16 x 4"	1-1/2	2-3/8	1,667	1,417	1,196	1,178
	5/16 x 5-1/8"	1-1/2	3-1/2	1,857	1,286	1,314	1,565
	5/16 x 6"	2	3-7/8	2,360	1,446	1,326	1,496
	3/8 x 3-1/8"	3-4	2-3/8	1,253	1,098	942	780
	3/8 x 4"	1-1/2	2-3/8	1,443	1,454	1,441	1,026
	3/8 x 5-1/8"	1-1/2	3-5/8	1,369	1,321	1,119	1,303
	3/8 x 6"	2	3-7/8	1,625	1,440	1,350	1,479
	3/8 x 7-1/4"	2-3/4	4-1/4	2,964	1,518	2,113	1,455
	3/8 x 8"	3-1/2	4-3/8				
	3/8 x 10"	3-1/2	6-1/4				
3/8 x 12"	3-1/2	8-3/8					
3/8 x 14-1/8"	3-1/2	10-5/8					
3/8 x 16"	3-1/2	12-1/8					
LPS	1/4 x 8"	5	2-7/8	1,789	1,093	1,243	1,285
LFT	3/8 x 8"	4	3-7/8	2,779	2,008	2,165	1,577
	3/8 x 10"	6	3-7/8				
	3/8 x 12"	8	3-3/4				
	3/8 x 15"	11	3-3/4				
	3/8 x 18"	14	4				
	3/8 x 20"	16	3-5/8				
PHEINOX	1/4 x 2-1/2"	3/4	1-5/8	1,077	925	812	672
	1/4 x 3-1/8"	3/4	2-3/8				
	5/16 x 3-1/8"	3/4	2-3/8	906	873	756	744
	5/16 x 4"	1-1/2	2-3/8	1,884	1,361	1,244	1,146
	5/16 x 6"	2	3-7/8	2,246	1,791	1,509	1,698
JTS	1/4 x 3-3/8"	1-3/4	1-5/8	830	983	619	841
	1/4 x 5"	1-3/4	3-1/4	1,203	1,184	752	1,103
	1/4 x 6-3/4"	1-3/4	5				

for S1: 1 inch = 25.4 mm

¹ Lateral load testing was performed in accordance with ASTM D 1761.

These figures are only offered as a guide and are not reduced by any safety factor. For safety factor requirements in your area, contact your local building official, architect or engineer.

PERFORMANCE TABLES

TABLE 5: CONNECTION GEOMETRY

CONNECTION GEOMETRY/CRITERIA	DIAMETERS ¹	RSS, LPS, JTS & PHEINOX 1/4" NOMINAL DIAMETER (INCHES)	RSS & PHEINOX 5/16" NOMINAL DIAMETER (INCHES)	RSS & LTF 3/8" NOMINAL DIAMETER (INCHES)
MINIMUM EDGE DISTANCE				
LOADING PARALLEL TO GRAIN	8	1-1/2	1-5/8	1-7/8
LOADING PERPENDICULAR TO GRAIN, LOADED EDGE	8	1-1/2	1-5/8	1-7/8
LOADING PERPENDICULAR TO GRAIN, UNLOADED EDGE	8	1-1/2	1-5/8	1-7/8
MINIMUM END DISTANCE				
TENSION LOAD PARALLEL TO GRAIN	15	2-5/8	3	3-3/8
COMPRESSION LOAD PARALLEL TO GRAIN	10	1-3/4	2	2-1/4
LOAD PERPENDICULAR TO GRAIN	10	1-3/4	2	2-1/4
SPACING (PITCH) BETWEEN FASTENERS IN A ROW				
PARALLEL TO GRAIN	15	2-5/8	3	3-3/8
PERPENDICULAR TO GRAIN	10	1-3/4	2	2-1/4
SPACING (GAGE) BETWEEN ROWS AND FASTENERS				
IN-LINE	5	7/8	1	1-1/8
STAGGERED	2.5	1/2	1/2	5/8
MINIMUM PENETRATION INTO MAIN MEMBER FOR SINGLE SHEAR CONNECTIONS				
	6 ²	1-1/8	1-1/4	1-3/8

for S1: 1 inch = 25.4 mm

¹ Diameter is the shank diameter as specified in Table 1.

² Reduce lateral load values provided in Table 4 when penetration is less than 10D.

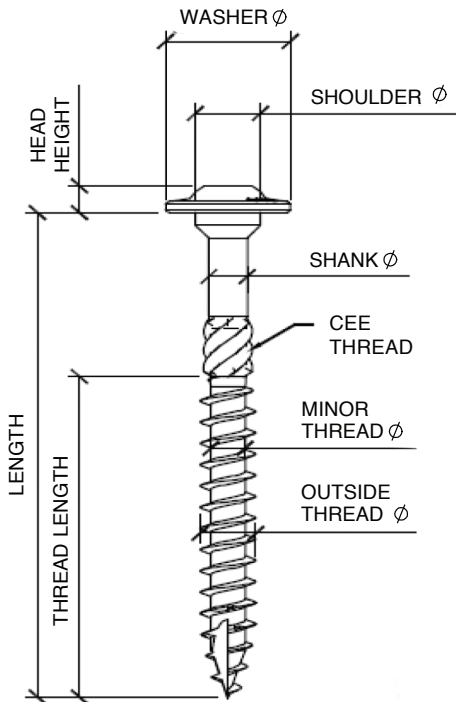

FIGURE 1 - FASTENER DIMENSIONS

SCREW TYPE	HEAD STAMP	WASHER Ø ± 0.020	HEAD HEIGHT ± 0.010	SHOULDER Ø ± 0.010	CEE THREAD ²
RSS 1/4 (6.0 mm)		0.533	0.110	0.244	LENGTH ≥ 3-1/8"
RSS 5/16 (7.0 mm)		0.620	0.157	0.301	LENGTH ≥ 3-1/8"
RSS 3/8 (8.0 mm)		0.689	0.181	0.364	LENGTH ≥ 3-1/8"
LTF 3/8 (8.0 mm)		0.688	0.181	0.364	LENGTH ≥ 3-1/8"
LPS 1/4 (6.0 mm)		0.535	0.090	0.244	NO
JTS 1/4 (6.3 mm)		0.534	0.090	0.244	LENGTH ≥ 5"

NOTES:

1. See table 1 for overall length, thread length, shank diameter, outside thread diameter and minor thread diameter.
2. CEE thread on screws with lengths greater than or equal to those indicated, not used for calculations.

PERFORMANCE TABLES

TABLE 1: FASTENER SPECIFICATIONS

FASTENER DESIGNATION	OVERALL LENGTH ¹ (INCHES)	LENGTH OF THREAD ² (INCHES)	MINOR THREAD DIAMETER ³ (INCHES)	SHANK DIAMETER ³ (INCHES)	OUTSIDE THREAD DIAMETER ³ (INCHES)	ALLOWABLE STEEL STRENGTH			
						BENDING YIELD STRENGTH ⁴ F _{yb} (PSI)	TENSILE (PSI) [POUNDS]	SHEAR (PSI) [POUNDS]	
R4	9 x 2"	2	1-1/4	0.117	0.130	0.174	167,160	61,760 [627]	39,660 [428]
	9 x 2-1/2"	2-3/8	1-5/8						
	9 x 2-3/4"	2-3/4	1-7/8						
	9 x 3-1/8"	3-1/8	2-1/8						
	10 x 2-1/2"	2-3/8	1-5/8	0.128	0.142	0.194	151,150	62,640 [846]	44,520 [542]
	10 x 2-3/4"	2-3/4	1-7/8						
	10 x 3-1/8"	3-1/8	2-1/8						
	10 x 3-1/2"	3-1/2	2-3/8						
	10 x 4"	3-7/8	2-5/8						
	10 x 4-3/4"	4-5/8	3	0.153	0.172	0.238	141,350	60,580 [1,134]	38,610 [655]
	12 x 2-1/2"	2-3/8	1-1/2						
	12 x 2-3/4"	2-3/4	1-3/4						
	12 x 3-1/8"	3-1/8	2-1/8						
	12 x 3-1/2"	3-1/2	2-3/8						
	12 x 4"	3-7/8	2-5/8						
	12 x 4-3/4"	4-5/8	3						
12 x 5-5/8"	5-1/2	3							
12 x 6-3/8"	6-1/4	3							
12 x 7-1/4"	7	3							
12 x 8"	7-7/8	2-5/8							
12 x 10"	9-3/4	2-3/4							
12 x 12"	11-3/4	2-3/4							
TRIM	8 x 2-1/2"	2-3/8	1-1/2	0.106	0.116	0.160	156,220	56,580 [499]	40,000 [360]
	8 x 2-3/4"	2-3/4	1-7/8						
	8 x 3-1/8"	3-1/8	2-1/8						
	9 x 2-1/2"	2-3/8	1-5/8	0.114	0.128	0.176	155,030	57,000 [576]	42,160 [425]
	9 x 2-3/4"	2-3/4	1-3/4						
	9 x 3-1/8"	3-1/8	2-1/8						
KAMELEON	9 x 2-1/2"	2-1/2	1-5/8	0.119	0.134	0.177	168,640	57,490 [634]	37,870 [437]
	9 x 2-3/4"	2-3/4	1-3/4						
	9 x 3-1/8"	3-1/8	2-1/8						

for S1: 1 inch = 25.4 mm; 1 psi = 6.9 kPa.

ULTIMATE LOAD VALUES TENSILE AND SHEAR

- ¹ Overall length of fastener is measured from the top of the head to bottom of the tip. See Figure 1.
- ² Length of thread includes tip. See detailed illustration, Figure 1.
- ³ Minor thread, shank and outside thread diameters are shown in table without manufacturing tolerances.
- ⁴ Bending yield strength determined in accordance with ASTM D 1575 using the minor thread diameter.

PERFORMANCE TABLES

SCREW TYPE	HEAD Ø	CEE-THREAD
R4 - #9 (4.5 mm)	0.328 ± 0.006	LENGTH = > 2"
R4 - #10 (5.0 mm)	0.368 ± 0.006	LENGTH = > 2"
R4 - #12 (6.0 mm)	0.439 ± 0.010	LENGTH = > 2"
TRIM - #8 (4.0 mm)	0.197 ± 0.006	N/A
TRIM - #9 (4.5 mm)	0.230 ± 0.006	N/A
KAMELEON - #9 (4.5 mm)	0.258 ± 0.006	ALL LENGTHS

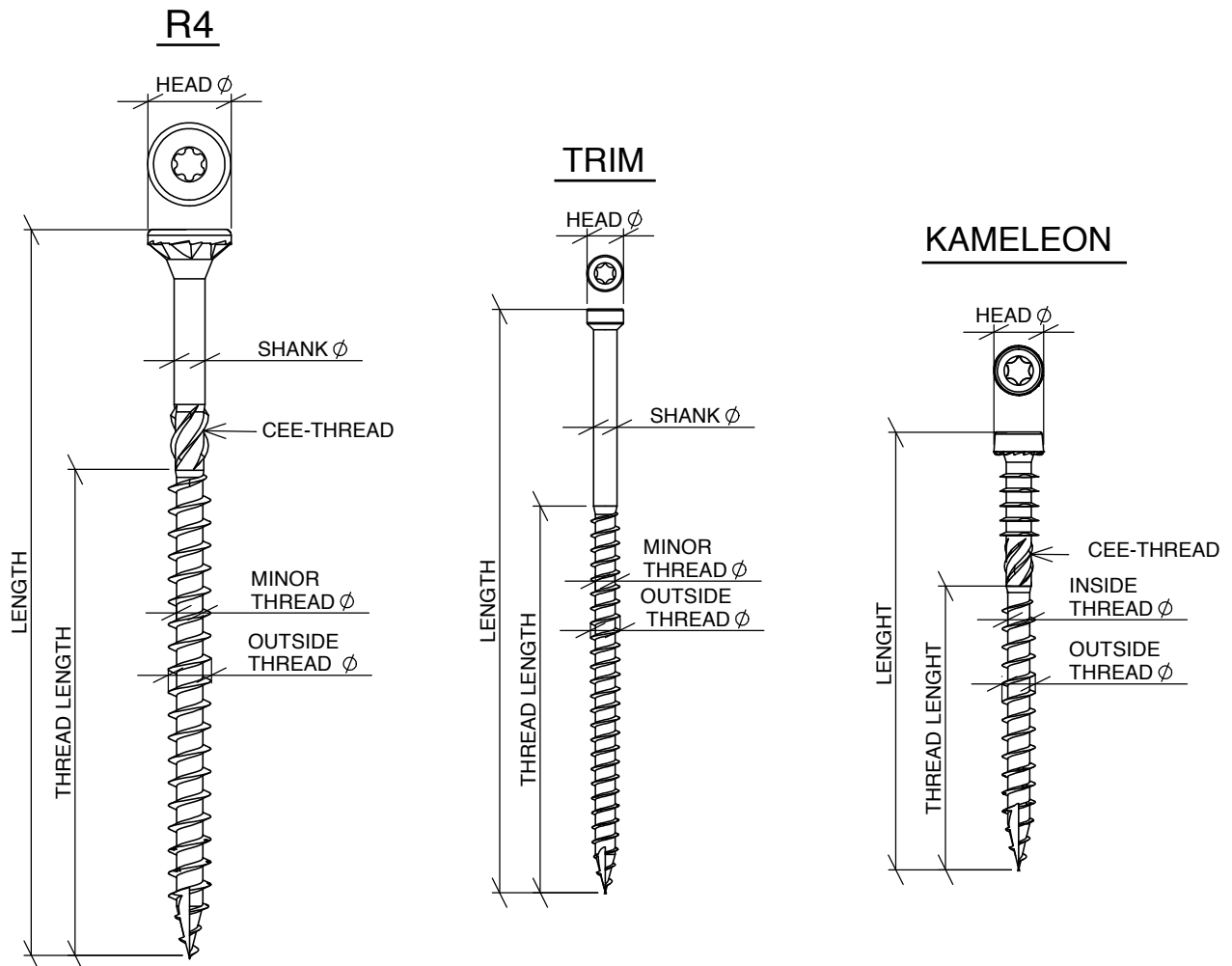

FIGURE 1 - FASTENER DIMENSIONS

NOTES:

1. See table 1 for overall length, thread length, shank diameter, outside thread diameter and minor thread diameter.
2. CEE thread on screws with lengths greater than or equal to those indicated, not used for calculations.
3. Dimensions given if not otherwise stated are in inches (for SI 1 inch = 25.4 mm)

PERFORMANCE TABLES

TABLE 2: ULTIMATE WITHDRAWAL VALUES (W)¹
[TABULATED WITHDRAWAL ULTIMATE VALUES (W) ARE IN POUNDS PER INCH OF THREAD PENETRATION INTO SIDE GRAIN OF MAIN MEMBER]

FASTENER DESIGNATION		WITHDRAWAL, W (LBS./IN.) FOR SPECIFIC GRAVITIES OF:
		0.67
R4	# 9	897
	# 10	1,244
	#12	1,273
TRIM	# 8	873
	# 9	1,106
KAMELEON	# 9	929

for S1: 1 inch = 25.4 mm; 1 lbf/in = 175.127 N/m.

¹ Fastener withdrawal was tested in accordance with ASTM D 1761.

TABLE 3: ULTIMATE PULL-THROUGH VALUES (P)¹
(TABULATED PULL-THROUGH ULTIMATE VALUES (P) ARE IN POUNDS PER INCH OF SIDE MEMBER THICKNESS)

FASTENER DESIGNATION		PULL-THROUGH, P (LBS./IN.) FOR SPECIFIC GRAVITIES OF:
		0.67
R4	# 9	1,038
	# 10	1,758
	#12	2,608
TRIM	# 8	393
	# 9	602
KAMELEON	# 9	917

for S1: 1 inch = 25.4 mm; 1 lbf/in = 175.127 N/m.

¹ Fastener pull-through testing was performed in accordance with ASTM D 1037.

PERFORMANCE TABLES

TABLE 4: REFERENCE LATERAL ULTIMATE VALUES (Z) FOR SINGLE SHEAR (TWO MEMBER) CONNECTIONS¹
[FOR SAWN LUMBER OR SCL WITH BOTH MEMBERS OF IDENTICAL SPECIFIC GRAVITY]

	FASTENER DESIGNATION	SIDE MEMBER THICKNESS, T_5 (INCHES)	FASTENER PENETRATION, P (INCHES)	REFERENCE LATERAL ULTIMATE VALUE, Z (POUNDS) FOR SPECIFIC
				0.67
				PARALLEL TO GRAIN, $Z_{ }$
R4	9 x 2"	25/32	1-1/8	876
	9 x 2-1/2"	25/32	1-1/2	1,015
	9 x 2-3/4"	25/32	2	
	9 x 3-1/8"	25/32	2-3/8	
	10 x 2-1/2"	25/32	1-1/2	1,045
	10 x 2-3/4"	25/32	2	1,016
	10 x 3-1/8"	25/32	2-3/8	
	10 x 3-1/2"	25/32	2-3/4	
	10 x 4"	25/32	3-1/8	
	10 x 4-3/4"	25/32	3-7/8	1,210
	12 x 2-1/2"	25/32	1-1/2	
	12 x 2-3/4"	25/32	2	
	12 x 3-1/8"	25/32	2-3/8	
	12 x 3-1/2"	25/32	2-3/4	
	12 x 4"	25/32	3-1/8	
	12 x 4-3/4"	25/32	3-7/8	
	12 x 5-5/8"	25/32	4-3/4	
	12 x 6-3/8"	25/32	5-1/2	
	12 x 7-1/4"	25/32	6-1/4	
	12 x 8"	25/32	7	
12 x 10"	25/32	9		
12 x 12"	25/32	11		
TRIM	8 x 2-1/2"	25/32	1-1/2	388
	8 x 2-3/4"	25/32	2	
	8 x 3-1/8"	25/32	2-1/2	421
	9 x 2-1/2"	25/32	1-1/2	607
	9 x 2-3/4"	25/32	2	
	9 x 3-1/8"	25/32	2-3/8	520
KAMELEON	9 x 2-1/2"	25/32	1-5/8	824
	9 x 2-3/4"	25/32	1-7/8	
	9 x 3-1/8"	25/32	2-3/8	794

for S1: 1 inch = 25.4 mm

¹ Lateral load testing was performed in accordance with ASTM D 1761.

Caliburn™, Caliburn™ PH, Caliburn XL™ Technical Fastener Data



PERFORMANCE TABLES

SCREW SIZE	EMBEDMENT DEPTH (IN.)	2000 PSI CONCRETE		BIT SIZE	DRILL SIZE
		TENSION/PULLOUT LBS.	SHEAR LBS.		
1/4 x 1-3/4"	1-1/2	1,655	1,505	T30	3/16"
1/4 x 2-1/4"	2	2,120	2,055	T30	3/16"
19/64 x 2-3/4"	2-1/2	2,209	3,135	T40	1/4"
19/64 x 3-1/2"	3-1/4	2,523	3,200	T40	1/4"
19/64 x 5"	4-3/4	5,724	3,300	T40	1/4"

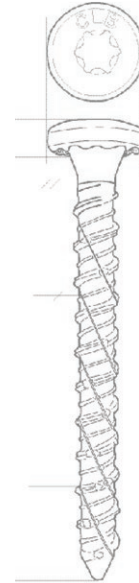

Note:

All values are based on close tolerance holes drilled a minimum of 1/4" deeper than embedment depth.

All listed values shown are average pull out and shear values for GRK's CALIBURN™, Caliburn™ PH and CALIBURN™ XL screws. Values will vary depending on a number of factors, including the quality of the concrete and size of the drill hole.

These figures are only offered as a guide. They are not guaranteed by GRK and not reduced by any safety factor.

For safety factor requirements in your area, contact your local building official, architect or engineer. Testing was performed according to the ASTM standard E-488-96. **The Caliburn™ XL was also an ICC Report ESR-3251.** For most current information and technical specifications (shear & tension) visit our website: www.grkfasteners.com.



LIABILITY AND WARRANTIES

GRK Fasteners™ is a distributor of commercial grade fasteners. Conformance to “IFI” specifications is formally requested from our suppliers. The parts that we supply are quality inspected by independent labs.

We maintain lot traceability on all products listed in this catalog as long as they are in their original bulk boxes. Certifications are maintained on all fasteners.

Hydrogen Embrittlement: We require our platers and suppliers of plated fasteners to bake case hardened parts to “IFI” specifications. However, this process does not guarantee that hydrogen embrittlement will not still be present after baking or that it will not occur at a later date while in service. Specialized testing or a substitute part may be required, depending on the application.

Liability: Claims against GRK Fasteners™ shall be limited to a refund or credit for the price billed or paid for faulty or incorrect merchandise. Seller shall not be responsible for buyer's manufacturing costs, labour, alternate purchases, extra freight, replating, plating, lost profit, good will, recall costs, or other incidental or consequential damages.

Warranties: GRK Fasteners™ (“GRK”) warrants to the first retail purchaser that its Climatek™ coated and PHEINOX™ stainless steel screws will not rust under normal environmental conditions when used in accordance with the recommendations listed in GRK's Screw Selection Guide. This warranty is not transferable.

Refunds: In order to receive a refund, the customer must return to us at least 50 of the defective screws (including screw heads) for verification.

THERE ARE NO UNDERSTANDINGS, AGREEMENTS, REPRESENTATIONS OR ADDITIONAL WARRANTIES, EXPRESSED OR IMPLIED (INCLUDING ANY REGARDING WARRANTIES OF MERCHANTABILITY OR FITNESS FOR A PARTICULAR PURPOSE), NOT SPECIFIED HEREIN, RESPECTING ANY SALE OF PRODUCTS BY GRK FASTENERS™, (TO THE EXTENT PERMITTED BY LAW).

NOTES

NOTES

Drive with Speed, Quality and Confidence...

FASTER INSTALLATIONS: No pre-drilling and faster driving. Innovative, patented features like our Zip-Tip™ and W-Cut threads are specially designed to bite instantly and with less torque for effortless fastening. This allows for almost twice as many screws drive per battery life, especially with larger diameter screws. See for your self by visiting our web site for the RSS vs. Lag Screw challenge.

NO STRIPPING, NO SPLITTING, NO HEAD POPS: Quality products mean no wasted time on the job site. Labour savings turn into dollar savings, more so over the life of the project. Recessed star drive screws eliminate any stripping when used with GRK bits. Our CEE thread prevents splitting of wood for a quality installed look. Case hardened steel screws will not break and heads won't pop during installation.

BUILDING CODE APPROVED: Confidence that our products will perform, even after the project is complete. All GRK screws have been evaluated for structural values in compliance with IBC/IRC specification. Our high tensile, torque and shear strength allow for immense drawing power out performing most other competitive fasteners. AC257 code approved for corrosion resistance in treated lumber, Climatek™ is the foremost name in corrosion protection and is exclusively available on GRK products. Originally designed for the Navy, GRK has adapted this coating for their fastener line-up and rigorously tests them to meet and exceed all standards. With a limited Lifetime Warranty, you can rest assured your installations will withstand the test of time.

Always build your project according to current ICC (International Code Council) specifications.



*GRK Fasteners™ is a proud member of the
North American Deck and Rail Association.*



GRK Fasteners Canada
ITW Construction Products
120 Travail Road
Markham, ON L3S 3J1

GRK Fasteners USA
ITW Renovations / Remodeling
955 National Pkwy, Suite 95500
Schaumburg, IL 60173

WWW.GRKFASTENERS.COM



Part# 99915CE 6/15